



Thetford Fridge terminology

Product lines

- DeLuxe line refrigerators with control knobs

All refrigerators which are supplied **WITHOUT** the LCD display control panel.



Manual Energy Control (MEC) Piëzo (V85)



Manual Energy Control (MEC) Piëzo



Manual Energy Control (MEC) Electronic



Manual Energy Control (MEC) Electronic
Isphording



- DeLuxe line refrigerators with LED



Smart Energy Selection (SES) LED



- Premium LCD line refrigerators

All refrigerators which are supplied **WITH** the LCD display control panel.



Either Electronic Energy Selection (EES) or Smart Energy Selection (SES) Automatic

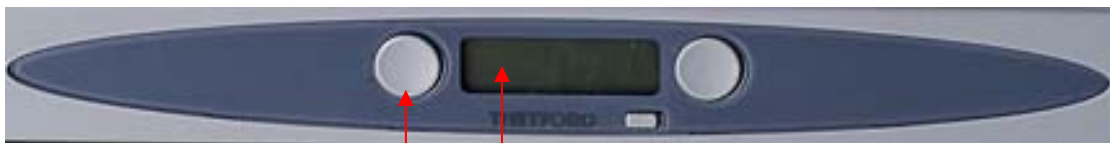

Press the left button (mode selection switch), when you see Auto on the left side of the display you have a SES version when not, you have an EES version

Error code 1

AC heater current is measured to be 75% below nominal current

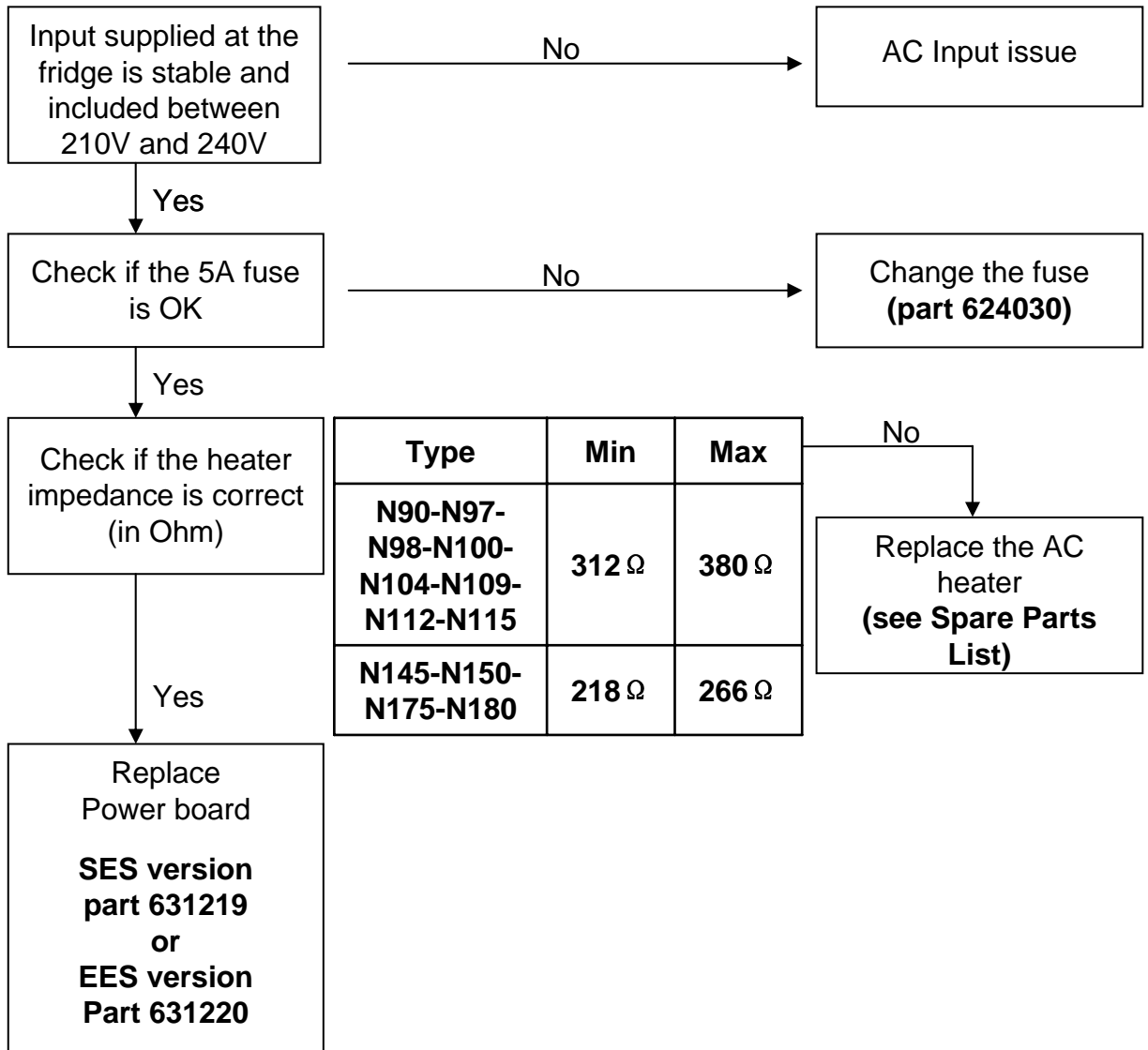

Error code 2

DC heater current is measured to be 75% below nominal current

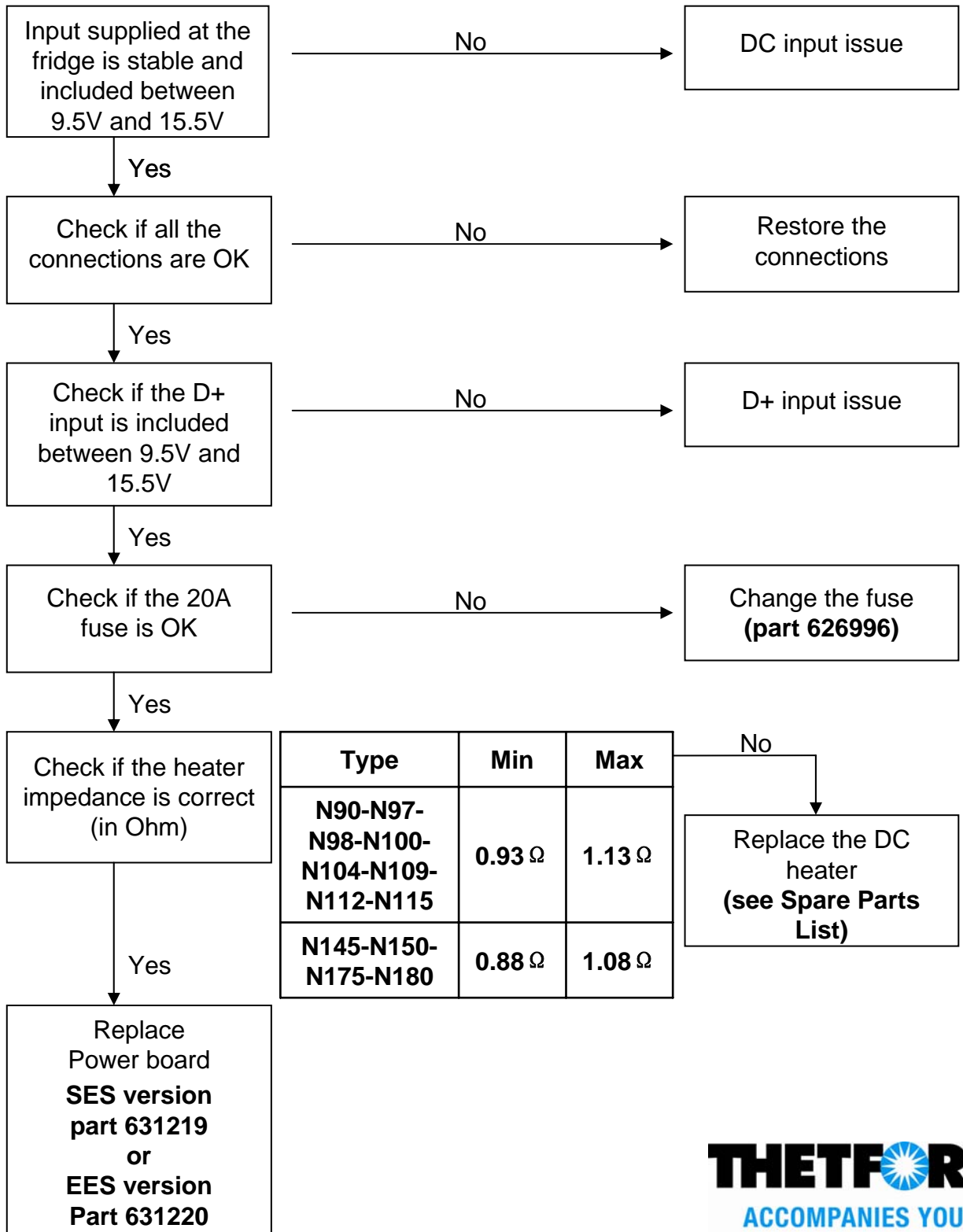

Error code 3 AC heater is ON when it should be OFF

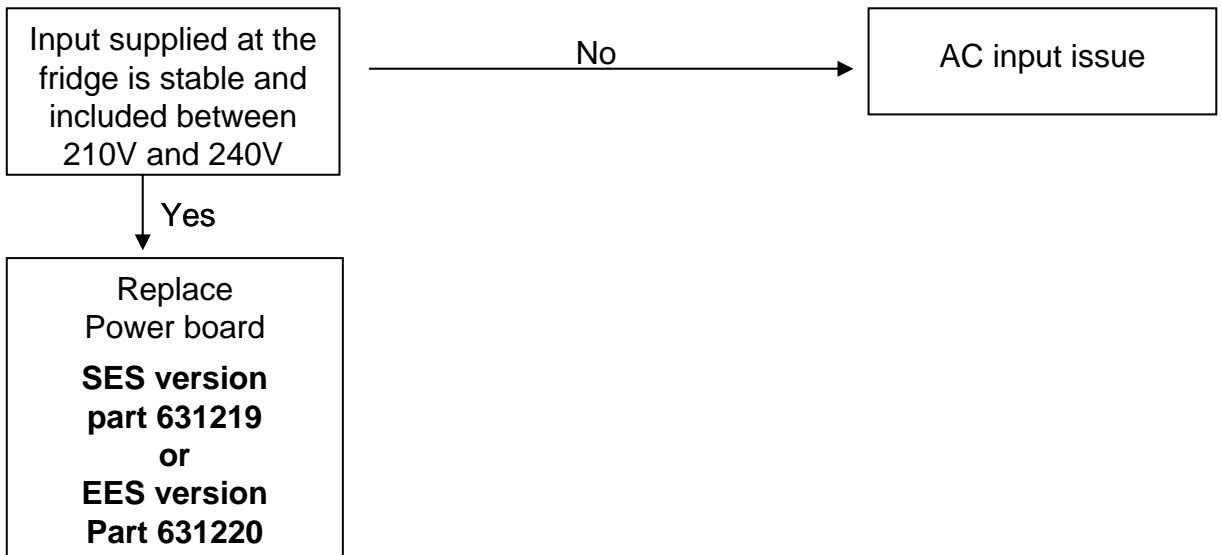

Error code 4 DC heater is ON when it should be OFF

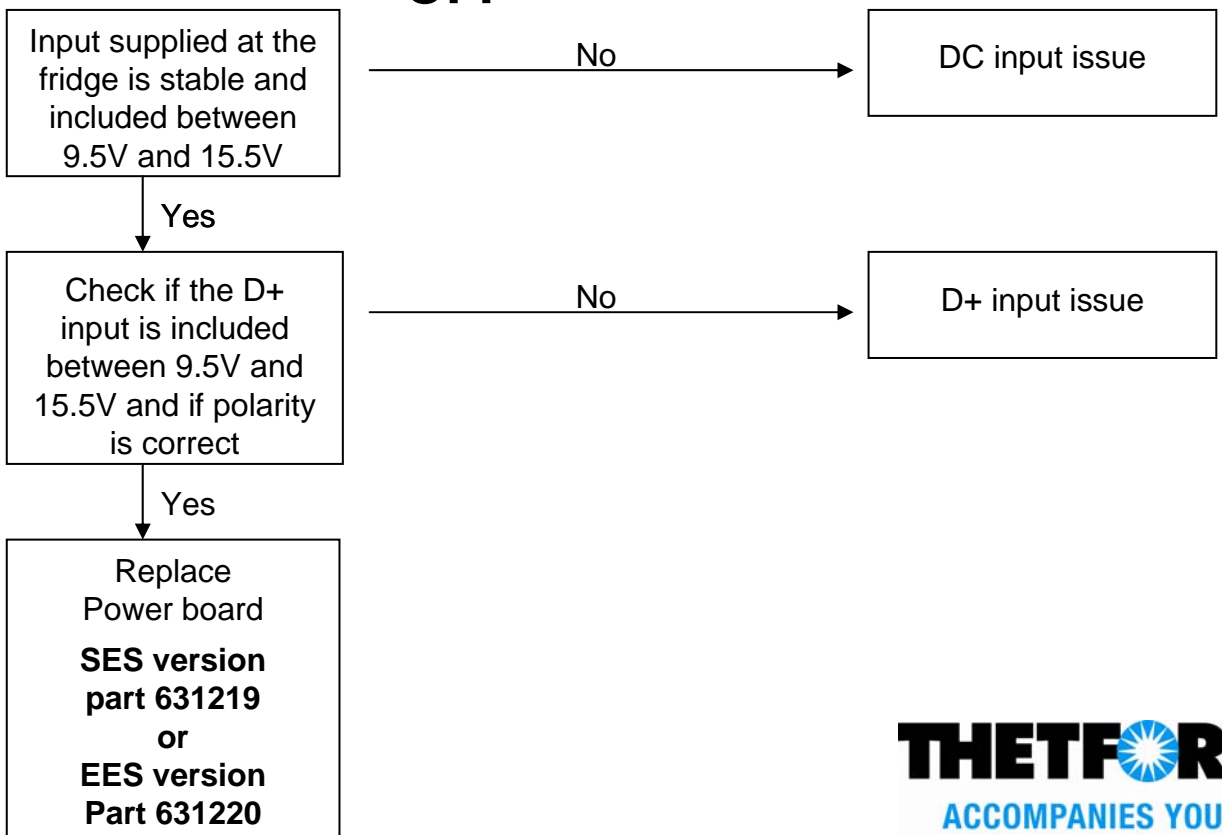



Error code 5 Senses flame when gas should be OFF

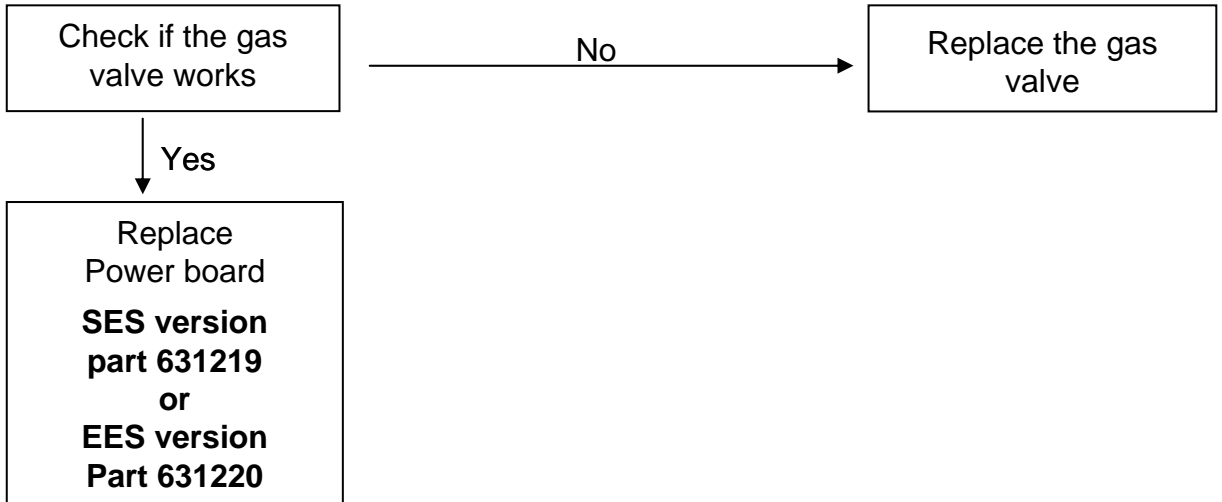

Error code 6 Senses gas output terminal ON when should be OFF

Replace Power board: - SES version part 631219
 - EES version part 631220

Error code 7 Senses gas output terminal OFF when should be ON

Replace Power board: - SES version part 631219
 - EES version part 631220

Error code 8

AC mains supply is below 20% nominal

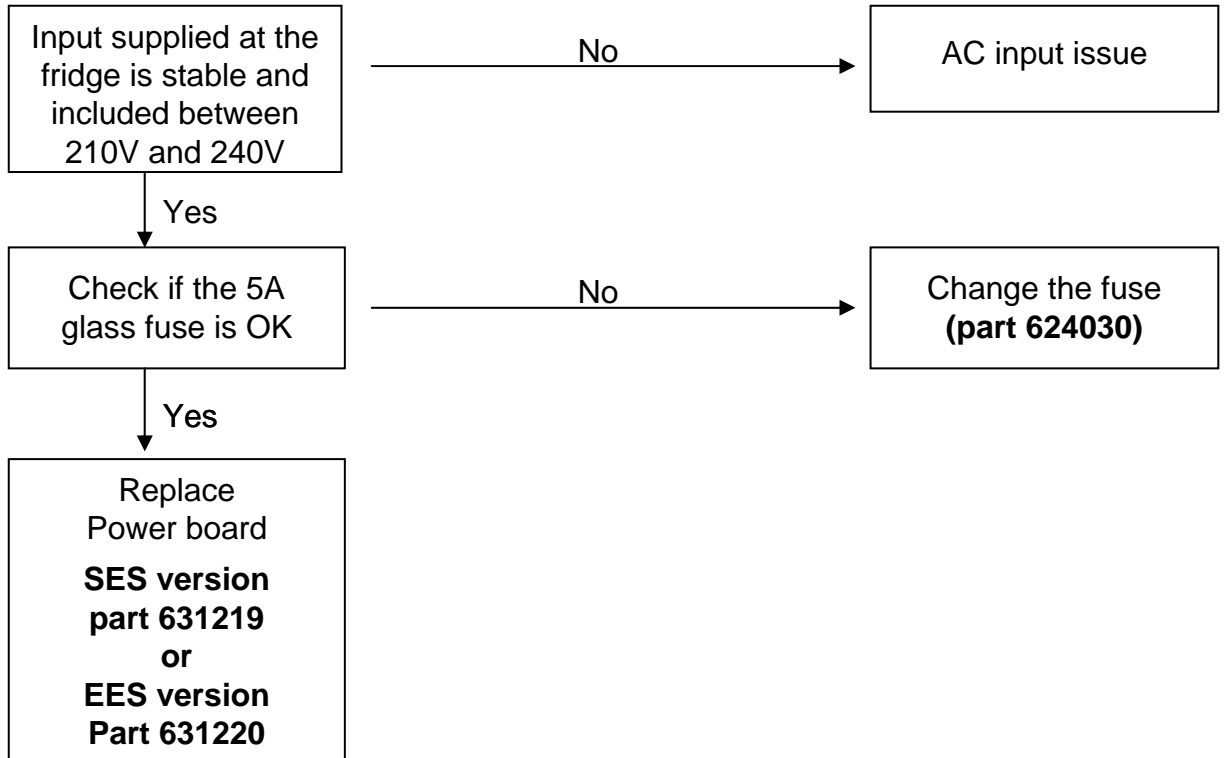

Error code 9

Gas lockout because flame fails to ignite after 30 seconds

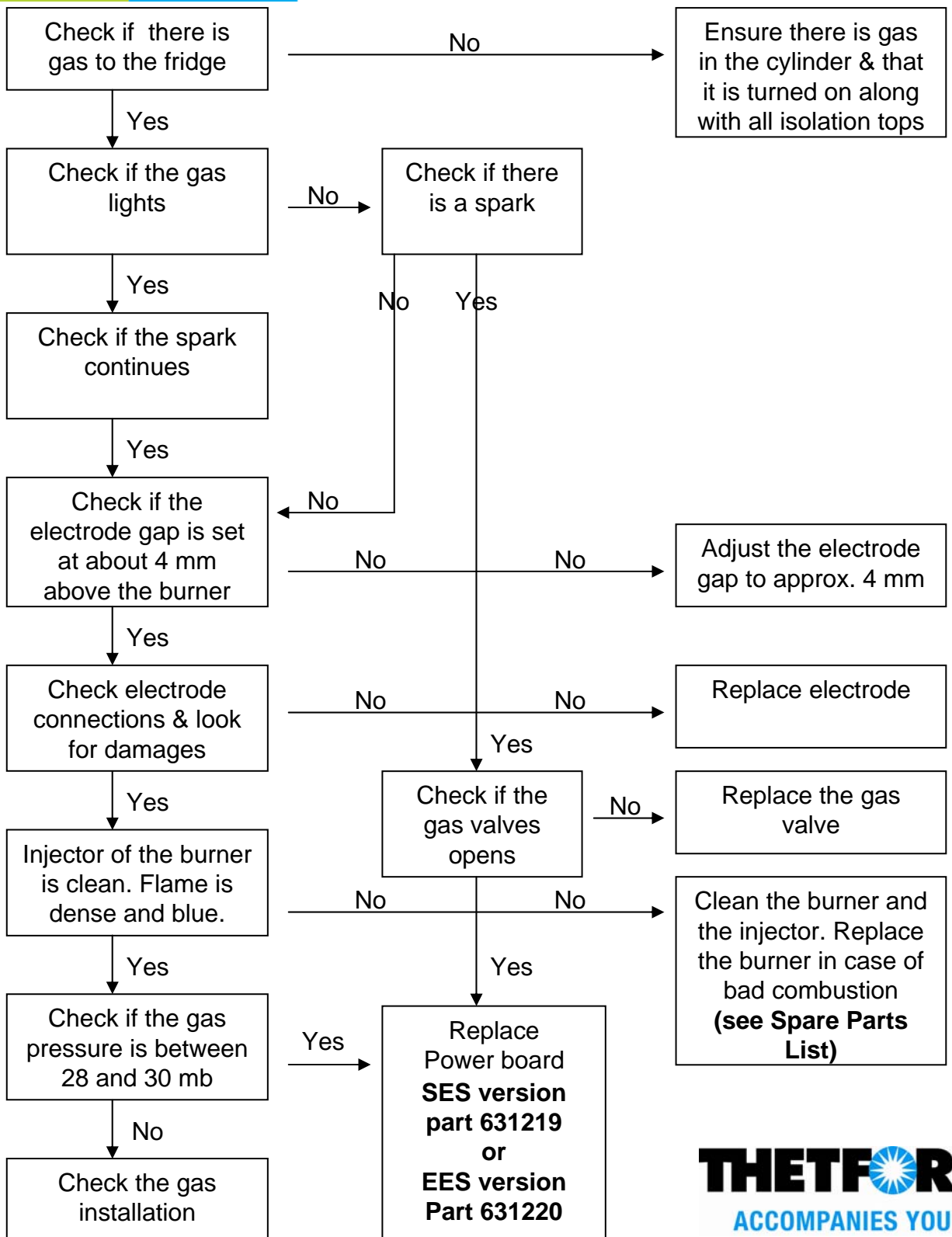

Error code 10

“No engine running” signal is Present and control is in Manual DC mode



To know if D+ polarity is good, select manually DC mode engine off.

If no error code occurs, that means the D+ input is versed.

Ensure power supply is capable to supply correct amperage.

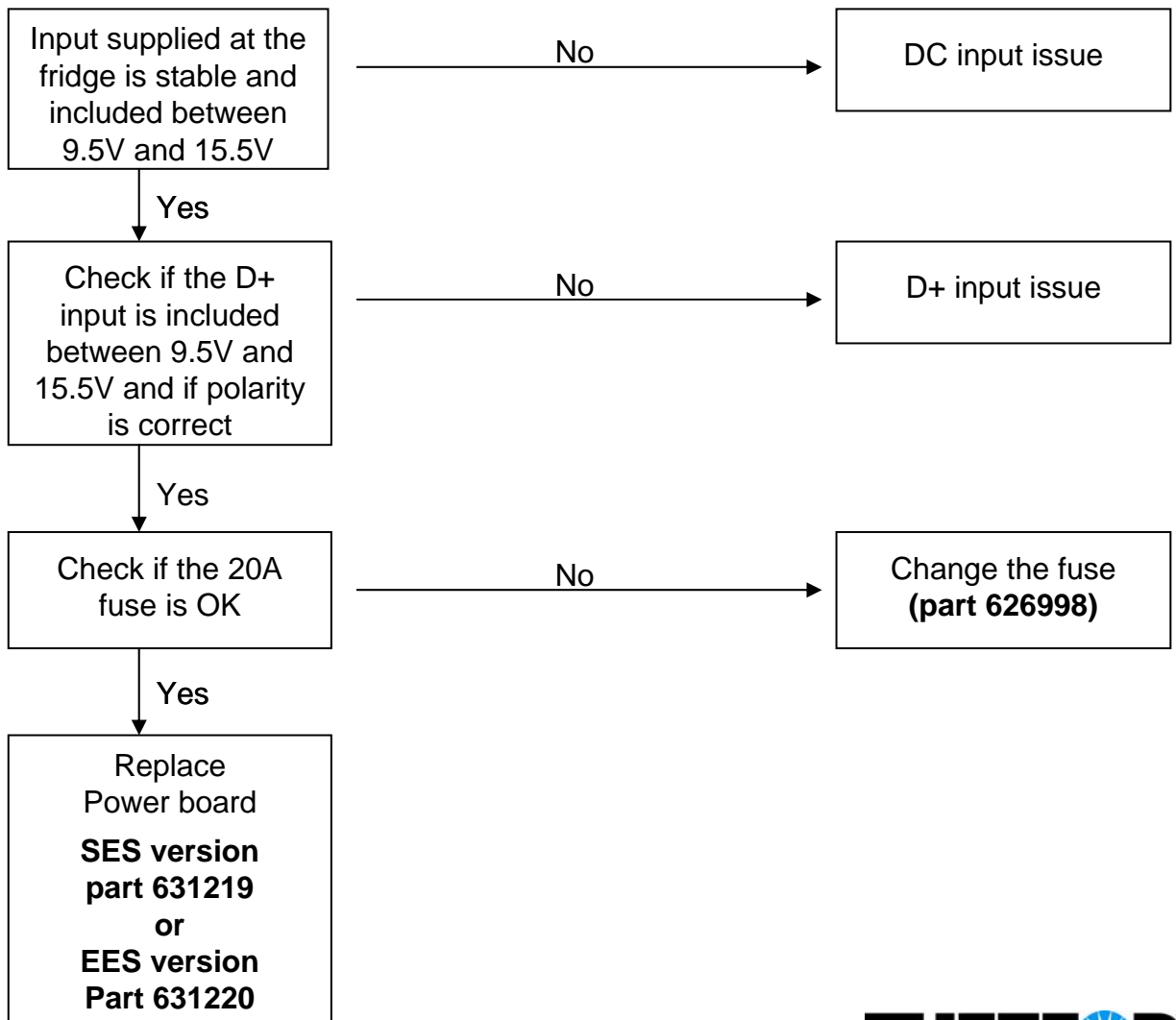

Error code 11

No energy source is available and control is on AUTO mode



Please make sure that all energy sources are available during the trial

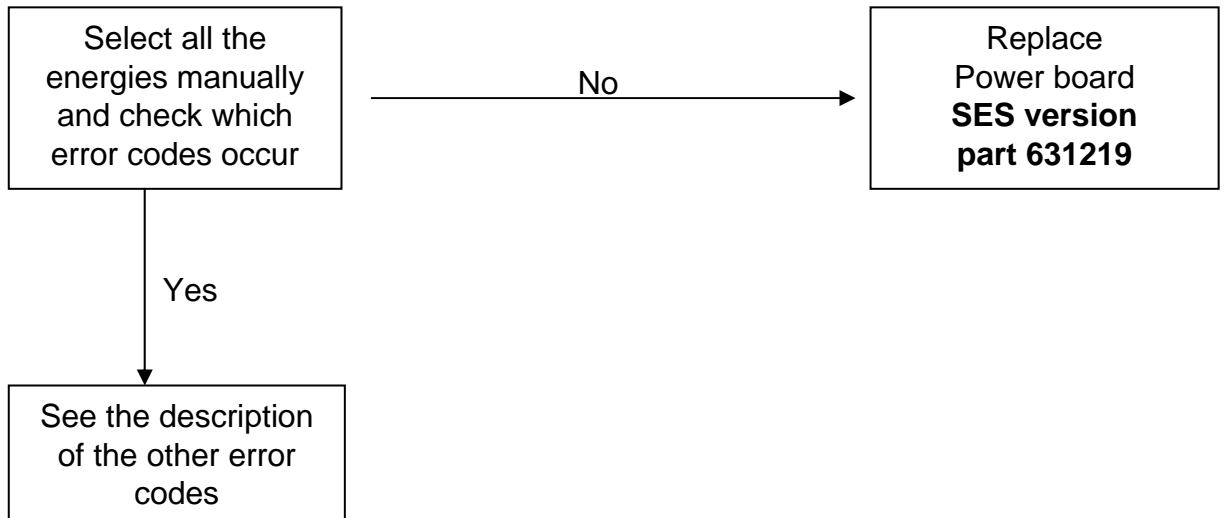

Error code 12

Supply voltage DC is out of range (9.5V – 15.5V)



If DC mode have been selected manually, the refrigerator is not switching automatically on another source of energy when the engine is off

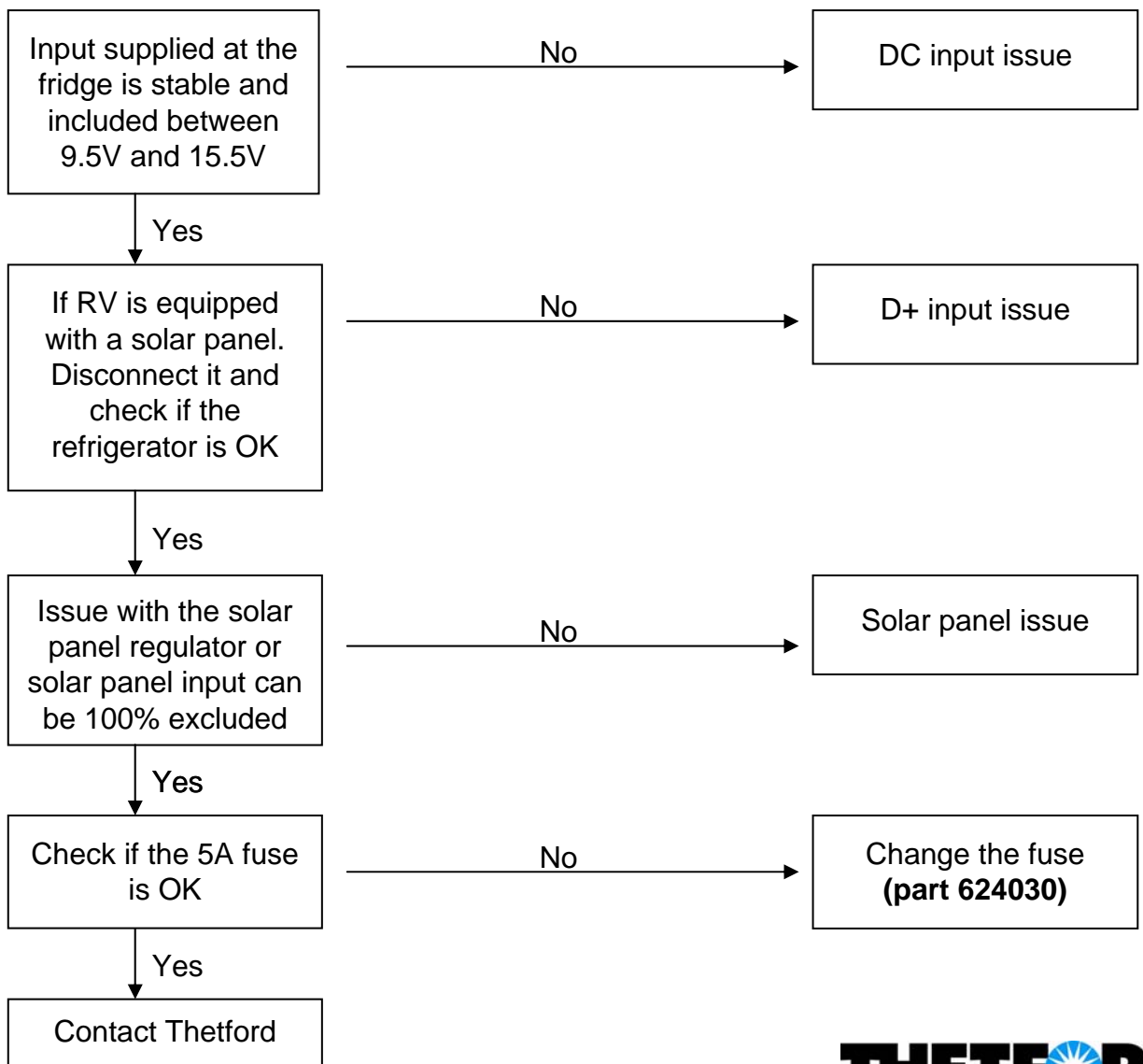



Error code 13

Thermistor fails, control automatically switches to backup mode (BOS)

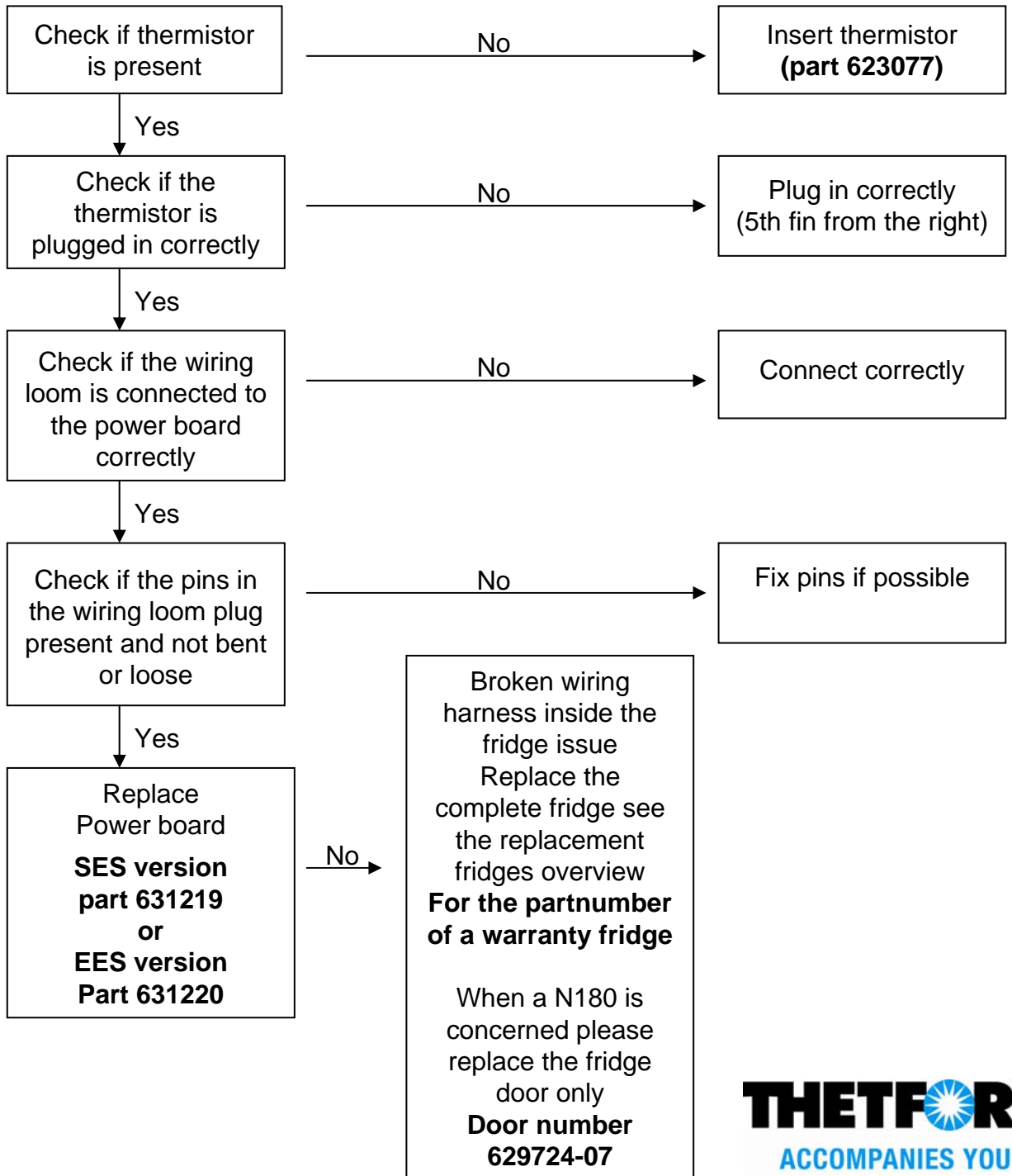

Error code 14

Display board and power board lost communication to each other

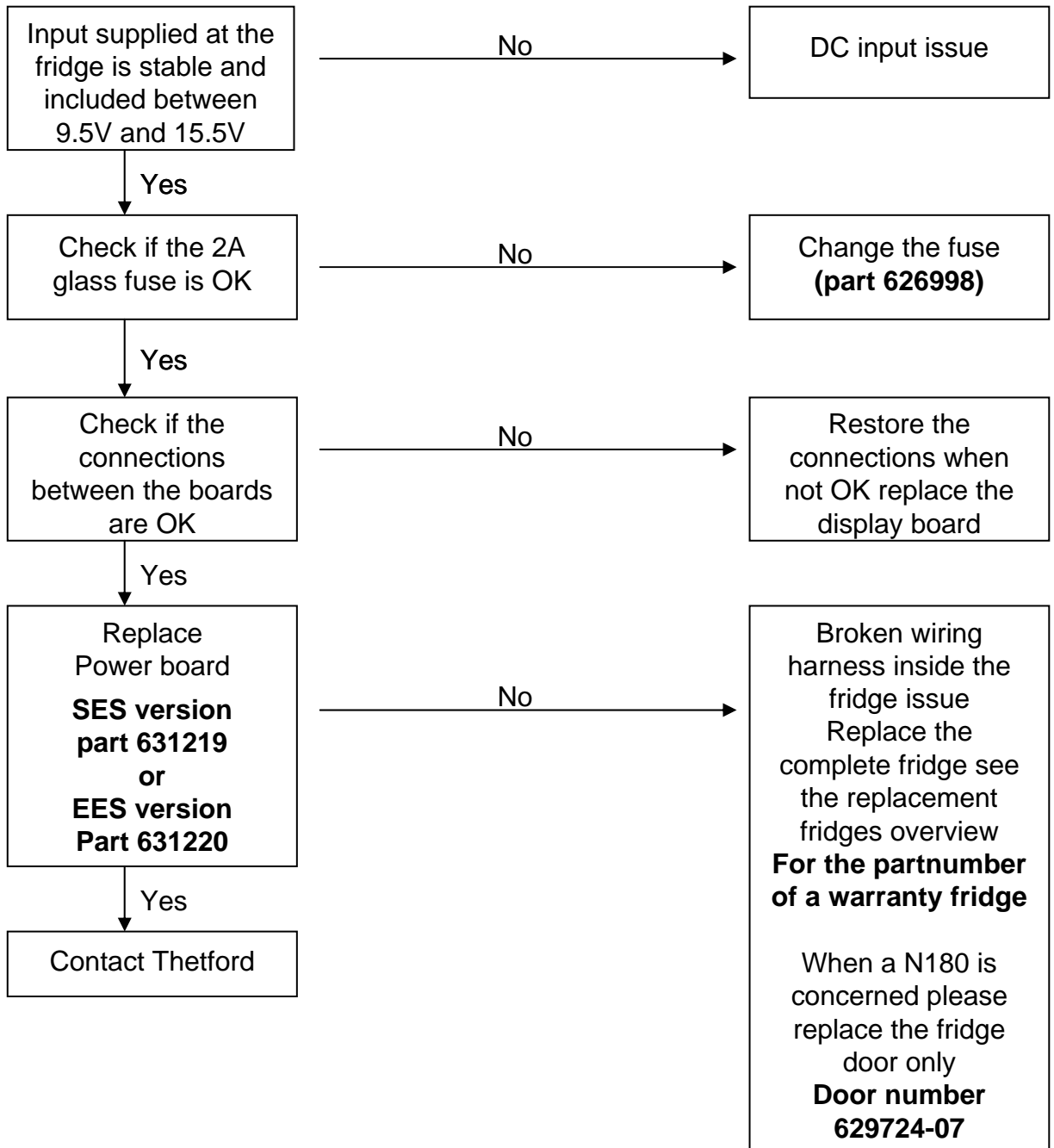



Lack of performance No error code

➤ On 12 Volts



Do the testing of the fridges on the manual mode

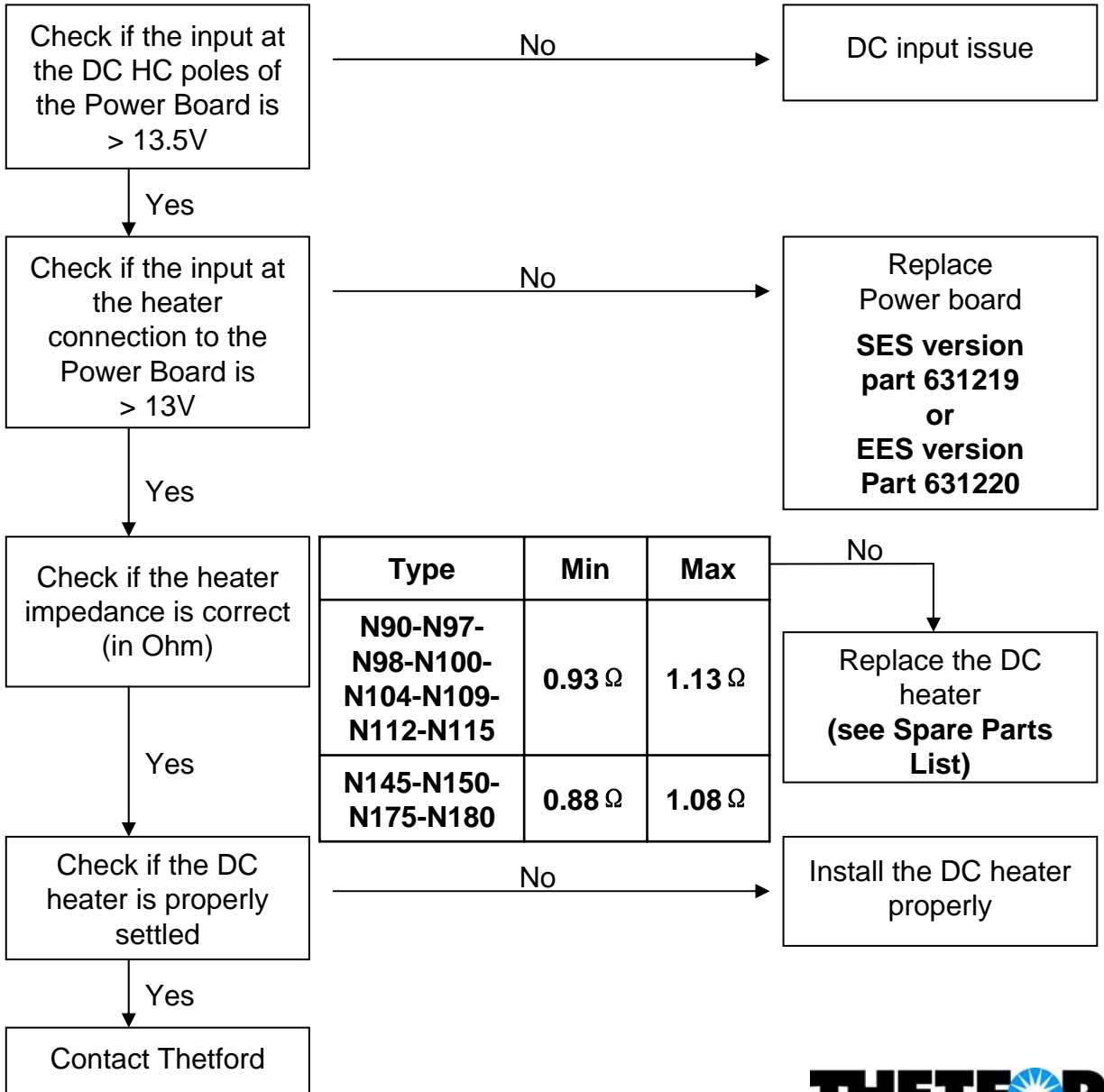



➤ On 230 Volts



Do the testing of the fridges on the manual mode

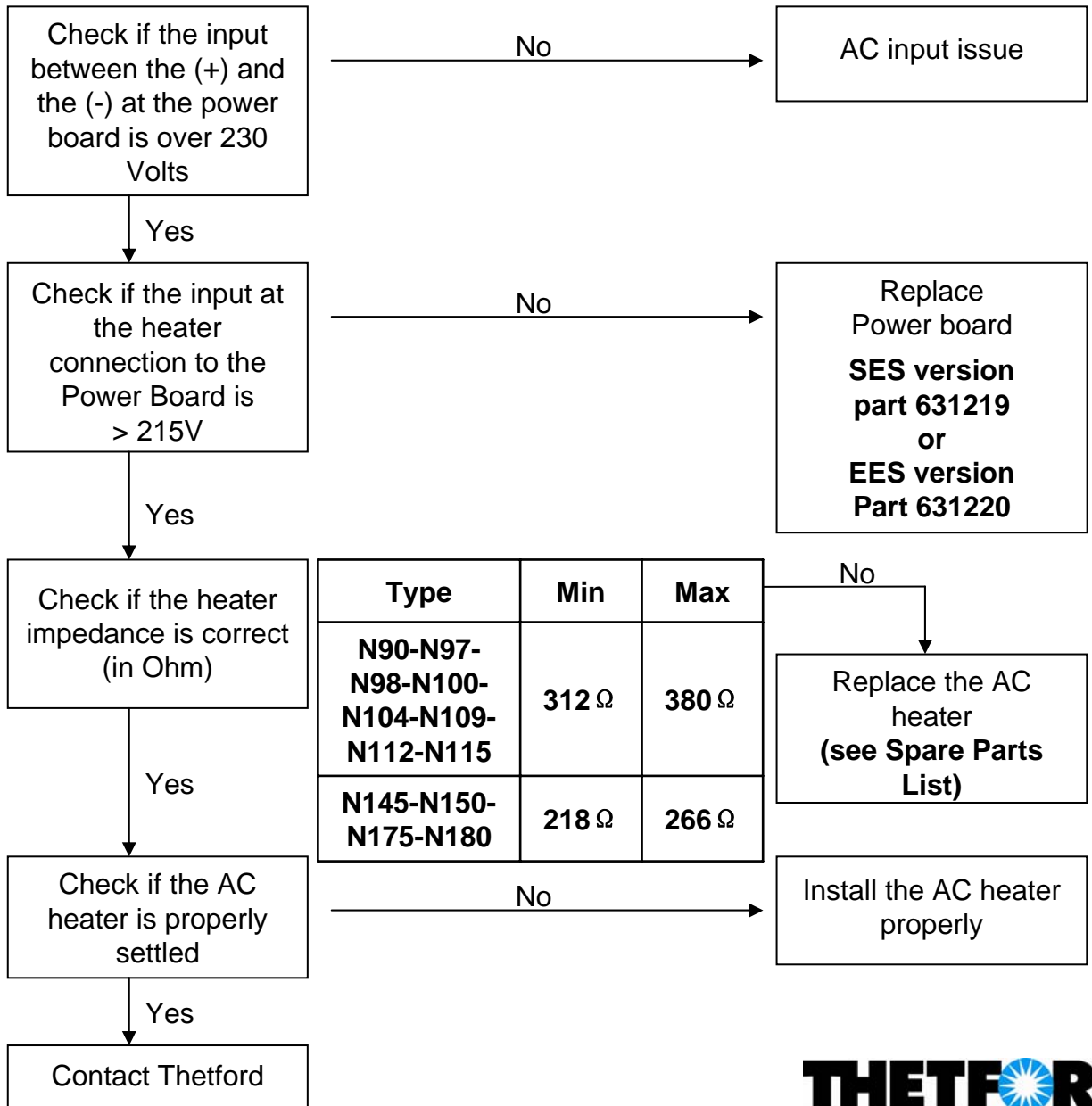



➤ On Gas



Do the testing of the fridges on the manual mode

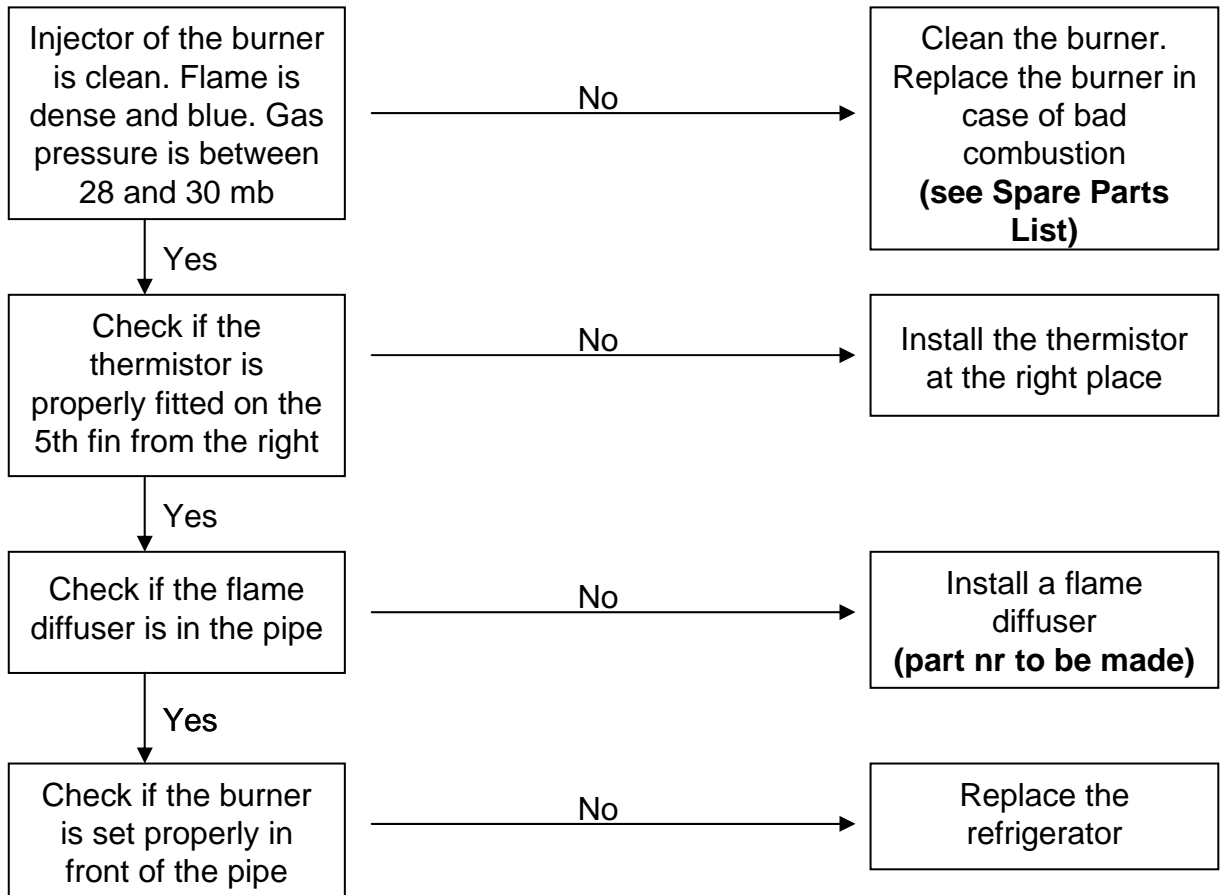

Power board on all LCD fridges

- Issue : A not replaceable fuse (F5) is blowing on the power boards, caused by wrong signal in circuit (f.i. short cut).
- Solution : Re-settable fuse integrated on the power board.
- Implementation : November 1st 2007
- Spare part nr. : 631219 and 631220
- Compensation : 30 minutes
- Repair-instruction : See repair instruction part



Power board old version
Underside of Top Half F5 fuse is at top centre



Modified power board with re-settable fuse shown in position





Corrosion on all Fridges shelves





- Issue : Corrosion on all shelves
- Solution : Re-inforced coating process to prevent rusting during life time product (7 years)
- Implementation : June 22nd 2007 for all shelves
- Spare part nr. : See spare part list
- Compensation : 5 minutes
- Repair-instruction : not included





Gas connections		
Picture	Tool	Torque
 Nut solenoid GV	Torque spanner 13mm	3 +1/-0 Nm
 Burner – orifice adapter	Torque spanner 16mm	7.5 +1/-0 Nm
 Gas tube assy – orifice adapter	Torque spanner 14mm	15 +1.5/-0 Nm



 <p>Gas tube assy – V85 GV</p>	<p>Torque spanner 11mm</p>	<p>10 +0.5/-0 Nm</p>
 <p>Gas inlet tube – V85 GV</p>	<p>Torque spanner 19mm</p>	<p>12 +2/-0 Nm</p>
 <p>Thermocouple – V85 Gasvalve</p>	<p>Torque spanner 8mm</p>	<p>1.5 +0.5/-0 Nm</p>
 <p>Gas inlet tube - LCD</p>	<p>Torque spanner 17mm</p>	<p>20 +2/ -0</p>