

AL-KO

QUALITY FOR LIFE



AKS 3004 STABILISER

HANDBOOK FOR THE AKS 3004 STABILISER

CONTENTS

- 3** REGULATIONS
- 4** RESTRICTIONS OF USE
- 5** SAFETY WARNINGS
- 6** FITMENT INSTRUCTIONS
- 8** FITMENT NOTES
- 10** OPERATING INSTRUCTIONS
- 14** SERVICING & CLEANING
- 19** FAQs
- 22** COMPLEMENTARY PRODUCTS

REGULATIONS

1. The AKS 3004 stabiliser must be used in conjunction with 50mm dia. towballs which conform to EC Directive 94/20 (DIN 74058 or local equivalent).
2. Suitable for attachment to drawbars or approved overrun braking equipment for single (and tandem axle) caravan/trailers, with a minimum weight of 200kg and a maximum permissible weight of 3000kg.
3. EC design approval has been given to the AL-KO AKS 3004 coupling under permit No. e1*94/20*0930*00.



RESTRICTIONS OF USE

1. The trailer coupling may only be connected to towing vehicles where the clearances for the stabiliser can be observed, in accordance with EC Directive 94/20 (DIN 74058). If these clearances are infringed by special attachments, then the use must be checked separately.

The area above the towball of the vehicle must be free from vehicle components or attachments (A) (e.g. spare wheels, platforms etc.)

The clearance for the stabiliser lever must be at least 330mm (B) + the stroke movement (D) (85mm-100mm), which equates to 440mm when used in conjunction with an AL-KO overrun.

Max. 50mm (C) clearance between the centre of the towball and top of the overrun assembly or fairing, to ensure both coupling handle and stabiliser lever do not foul on operation.

Maintain the same clearances for other manufacturers' overrun assemblies.

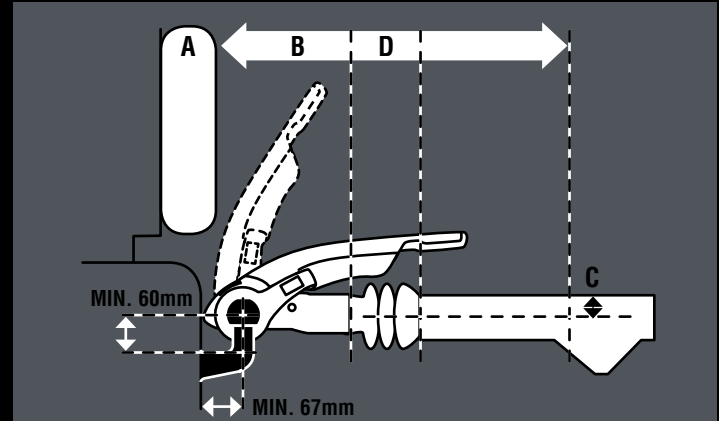
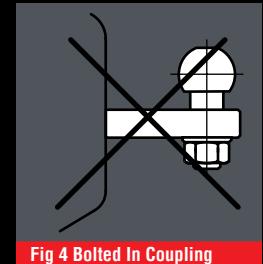
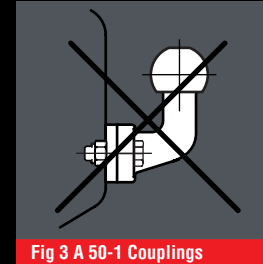
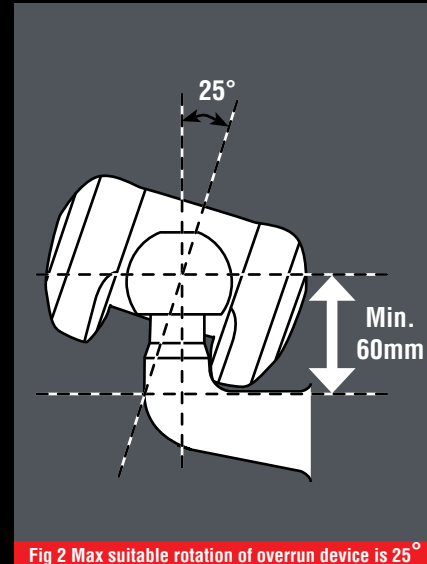

Fig 1 Necessary Clearances

2. May not be suitable for use with overrun devices which can revolve above 25° (Fig 2) or BPW overruns fitted with gas strut handbrakes from 2001 model year onwards. (If in any doubt about usage consult your manufacturer).
3. Swan Neck towbars (fixed or detachable) are suitable for use with the AKS 3004 providing they comply to EC Directive 94/20 and have the required minimum 60mm clearance, measured from the centre of the towball (Fig 2).

SAFETY WARNINGS

1. In accordance with EC Directive 94/20, couplings of type A 50-1 cannot be used (see Fig 3), your warranty will be invalid if this type of towball is used.
2. For UK use, use the extended neck towball (type A50-X).
3. A bolted-in type ball coupling (Fig 4) is only permissible if the thread is locked or welded.
4. The AKS 3004 cannot be used with a laterally attached reversing lever, on the left side, when facing the direction of traffic.
5. The towball must be free from grease, paint and other residue, otherwise the stabilising effect is greatly reduced. **Coated towballs must have the coating completely removed (use 100 or 120 grain emery paper). If this is not done increased towball wear will occur and may cause damage, or reduce the efficiency of the stabiliser.**
6. If friction pads become contaminated with grease, they should be replaced.
7. The AKS 3004 should only be operated by one person, when opening or closing the handle, to reduce injury risks.



FITMENT INSTRUCTIONS

- 1 Before starting you must ensure the handbrake is on.
- 2 Unscrew the two nuts on the coupling head and remove the front bolt.
- 3 Take the dowel provided and hammer it through the coupling head to push the rear bolt out.
- 4 Once the dowel has replaced the bolt inside the coupling head you should be able to remove the rear bolt completely. You may need to push the coupling head to ease the process.
- 5 Slide the coupling head off of the overrun.
- 6 DO NOT place the AKS 3004 Stabiliser over the overrun.
- 7 The new AKS 3004 Stabiliser slides onto the overrun.
- 8 Push the stabiliser until its holes line up with the holes in the overrun.
- 9 Take the two new bolts supplied with the stabiliser, and insert the bolt with the washer into the front hole.
- 10 Hammer the bolt without the washer into the rear hole, forcing the dowel out of the other side.
- 11 Screw the supplied nuts onto both bolts.
- 12 Tighten both bolts with a torque wrench to 86Nm.



Step 1



Step 3



Step 2



Step 4

FITMENT INSTRUCTIONS



Step 5



Step 7



Step 9



Step 11



Step 6



Step 8



Step 10



Step 12

FITMENT NOTES

- 1 Always insert the bolts from the right hand side (when facing caravan), to ensure the correct clearances are allowed if fitting AL-KO Security Device (sold separately).
- 2 **For non AL-KO overruns**, with one horizontal and one vertical fixing bolt, insert the front bolt through the washer, overrun shaft and internal spacer (where used). Finally, fit hexagonal self-locking nut and torque to 120Nm for 10,9 class bolts or 86Nm for 8,8 class bolts.

Take Mushroom Headed Coachbolt and insert from top, fit original curved washer (from your overrun) and hexagonal self-locking nut and torque to 86Nm (8,8 class bolt supplied).

NOTE

The class of bolt will be stamped onto the bolt head.

PLEASE NOTE THAT ON MOST OVERRUN ASSEMBLIES, THE DAMPER IS SECURED BY THE REAR RETAINING BOLT AND TELESCOPES OUT INDEPENDENTLY.

NOTE: The AKS 3004 is designed for 50mm draw shafts. For smaller diameter shafts, spacers must be used. These are provided with your stabiliser kit.

Shaft Dia. Requirements

50mm	No spacers required
35mm	7.5mm spacer
46mm	2.0mm spacer - non AL-KO

FITMENT NOTES

It may also be necessary to replace the gaiter according to the different diameter draw shafts, see below for details (refers to AL-KO overruns only).

Shaft Dia. Gaiter Amendments

35mm	No amendments necessary, use existing gaiter. Fit smaller diameter of gaiter flush to end of stabiliser and secure larger diameter of gaiter with the retaining ring included with this kit.
50mm	Gaiters as per Fig 5/Item A, this is secured immediately after the coupling and can therefore be used again. Gaiters as per Fig 5/Item B, cannot be used again. Replace with gaiter included with this kit.

FOR YOUR OWN SAFETY PLEASE CHECK THE FOLLOWING:

- Ensure in both cases that the damper is correctly connected, push the drawshaft in and out - you will feel resistance when the damper is correctly located.
- Self-locking nuts must only be used once - if removed replaced with new ones.

SPARE PARTS

- Spare parts are safety critical! For this reason when fitting spare parts in our products we recommend the use of original AL-KO parts. The reliability, safety and suitability of parts designed especially for our products, has been determined using a special test procedure. In spite of constantly monitoring the market we are unable to assess or vouch for any other products.
- Repairs should only be carried out by trained and qualified workshop personnel. A list of AL-KO Approved Service Centres is available online at www.al-ko.co.uk.
- Always quote the ETI number printed on this product, when enquiring about spare parts.

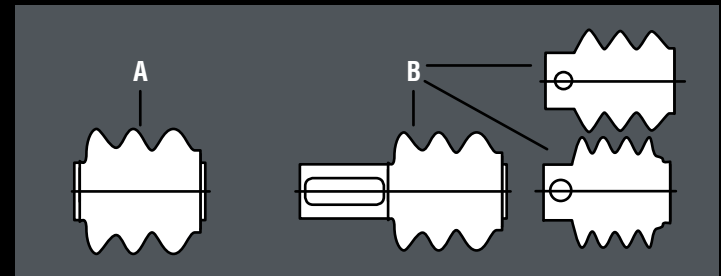

Fig 5 Gaiter Amendments

OPERATING INSTRUCTIONS

AKS 3004 SPECIFICATIONS

Coupling Handle (Fig 7/Item 1)

Stabiliser Lever (Fig 7/Item 2)

PREPARATION FOR COUPLING/UNCOUPLING

The Stabiliser lever (Fig 7/Item 2) must be in the uppermost position (open).

COUPLING UP

Pull the coupling handle (Fig 8/Item 1) up in the direction of arrow. The coupling mechanism has an open position, as long as the AKS 3004 is not placed on the ball, the handle will remain open. Put the opened coupling onto the clean towball. The handle must now make an audible click and return to the flat position.

WARNING

The coupling is correctly engaged when the green edge of the safety indicator button is visible (Fig 9/Item 2).

STABILISER UNIT

To operate the stabiliser (once coupled to the towball), simply press the stabiliser lever down as far as it will go (Fig 9/Item 3).

To ensure the stabiliser is correctly coupled, check the arrowhead lines up with the black line marked 2 (Fig 9 /Item 4 and Fig 13/C).

UNCOUPLING

Pull the stabiliser lever up as far as it will go, open the coupling handle and lift the AKS 3004 from the towball. With larger nose loads, coupling and uncoupling can be made easier by using the jockey wheel to assist lifting.

NOTE

The friction pads (Fig 10/Items 1, 2 & 3) are pressed against the towball and hence generate a stabilising/damping force. These pads are therefore subject to wear over time, however they will have a long service life (circa.30,000 miles), provided they are well maintained and kept free of grease/dirt.

OPERATING INSTRUCTIONS

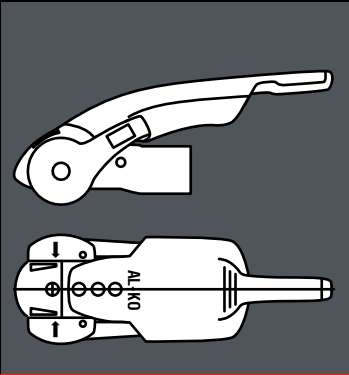

Fig 6 AKS 3004 Stabiliser

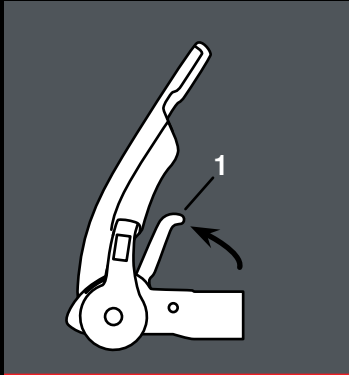

Fig 8 Pull Coupling Handle Up

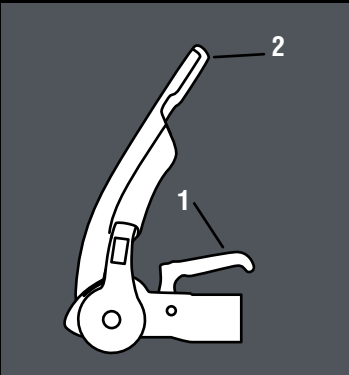

Fig 7 Raise Stabiliser Lever

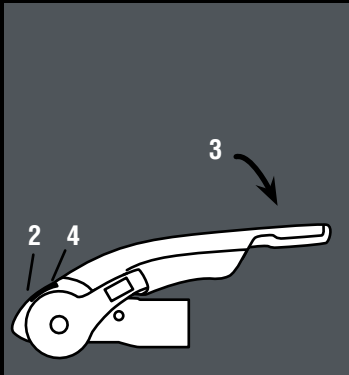

Fig 9 Correct Engagement With Towball

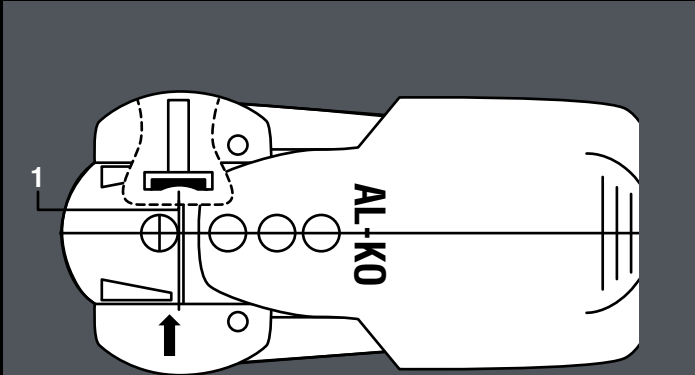
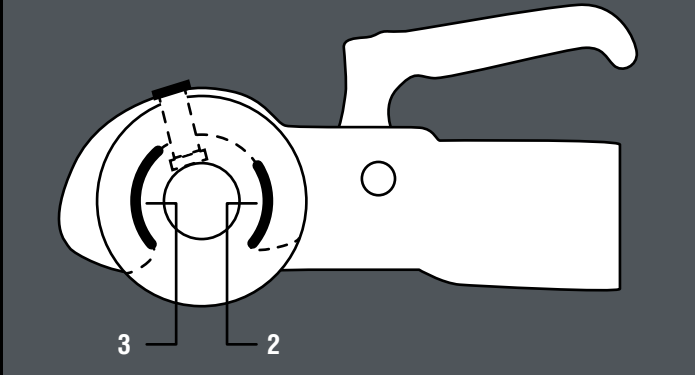

Fig 10 AKS 3004 Friction Pads



OPERATING INSTRUCTIONS

MANOEUVRING

For easier manoeuvring (on campsites etc), pull the stabiliser lever to the 'up' position.

Please do not use the stabiliser lever as a manoeuvring handle. Please use the handles on the caravan or fit the AL-KO manoeuvring handle to your jockey wheel (available separately).

1. During opening or closing, the AKS must only be operated by one person.
2. Press stabiliser lever down by hand force only. **DO NOT** use your foot or an extension bar, this will damage the components (Fig 11).
3. When opening or closing the stabiliser lever, please ensure your hand does not touch the coupling handle - you may accidentally trap your fingers (Fig 11).

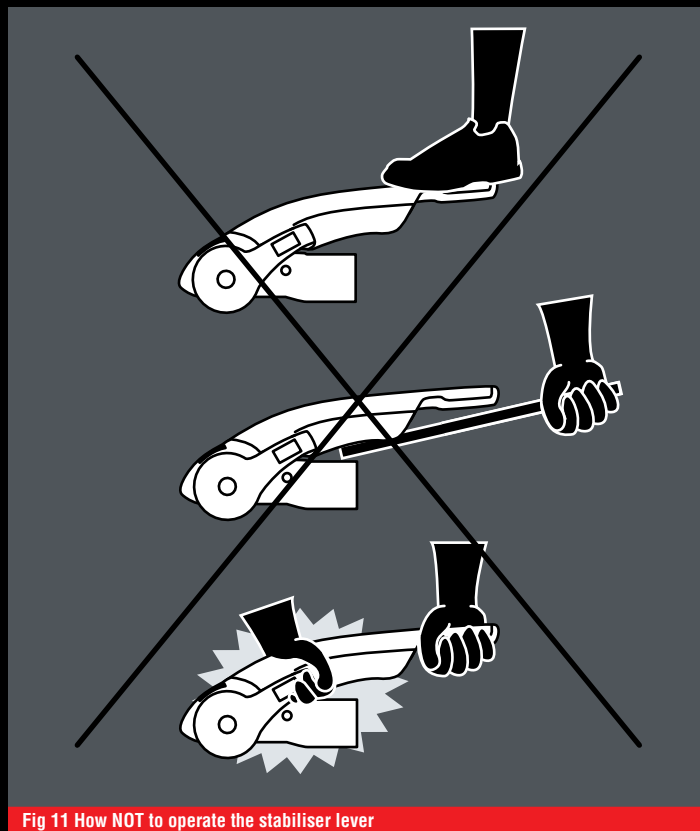

Fig 11 How NOT to operate the stabiliser lever

OPERATING INSTRUCTIONS

NOISES WHILST DRIVING

As a rule, the friction pads of the AKS 3004 do not make a noise during driving. Any clicking, creaking or squeaking noises that do arise may be due to the following:

- a. Foreign bodies, dirt or exhaust particle build up between the friction pad and towball.
- b. Dry operation of the drawshaft inside the overrun device.
- c. A detachable towball which has too much play in the locking mechanism.

REMEDIAL ACTION

- a. Clean the towball and friction pads before each journey by lightly rubbing the surfaces with a light emery paper (100-120 grit) or use brake cleaning fluid to remove the build up.
- b. Lubricate the drawshaft sleeve via the grease nipples. In addition, push the gaiter forward and grease (DIN 51 825 KTA 3K) the exposed part of the shaft (Fig 12).
- c. Visit a specialist workshop to have the ball holding area checked for damage and the locking mechanism for function. If necessary, change the towball.

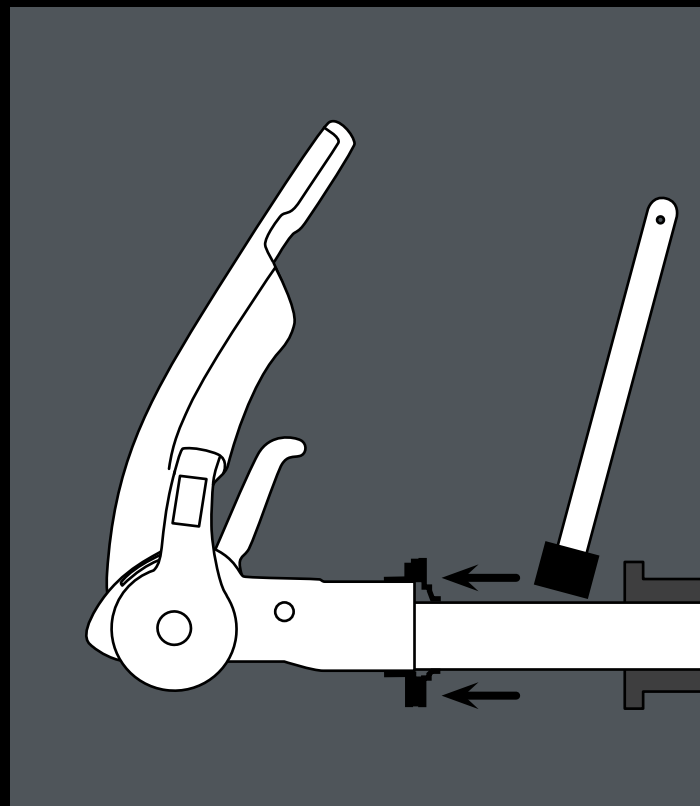

Fig 12 Remedial Action

SERVICING AND CLEANING

CHECKING THE EFFICIENCY OF THE SIDE FRICTION PADS

1. Check that the stabiliser is correctly coupled by ensuring the coupling handle is fully down and the red indicator button is in the raised position.
2. Push the stabiliser lever (Fig 13/Item 1) down until resistance is felt (i.e. The friction pads are in contact with the ball but not yet under pressure).
3. Check the position of the arrowhead on the arm of the stabiliser. If it lines up with the two green lines then the friction pads are still as new (Fig 13/A).
4. If the arrowhead lines up with the two red lines then the friction pads are worn and should be replaced immediately (Fig 13/B).

NOTE

When the stabiliser lever is correctly applied, the arrowhead should line up with the black line marked 2 (Fig 13/C).

NOTE

The friction pads do not require any form of lubrication and should be cleaned with a fine emery paper prior to every journey. It is not necessary to adjust the friction pads.

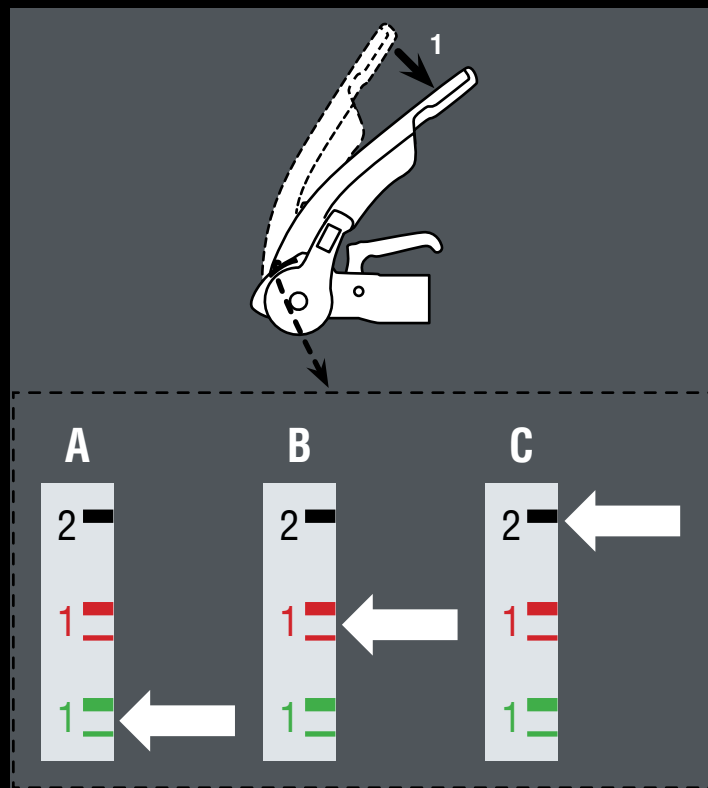

Fig 13 Checking Left/Right Friction Pads

SERVICING AND CLEANING

FRICTION PAD REPLACEMENT (SIDE)

(Replace one at a time)

1. Uncouple the AKS 3004 stabiliser.
2. Remove protective caps (Fig 14/Item 1) with the aid of a small screwdriver.
3. Press worn out pad inwards and remove (use punch and hammer) (Fig 14/Item 2).
4. Insert new friction pad from below (after first re-inserting shim washers if they were present) and press in as far as it will go (Fig 14/Item 3 & Fig 15).

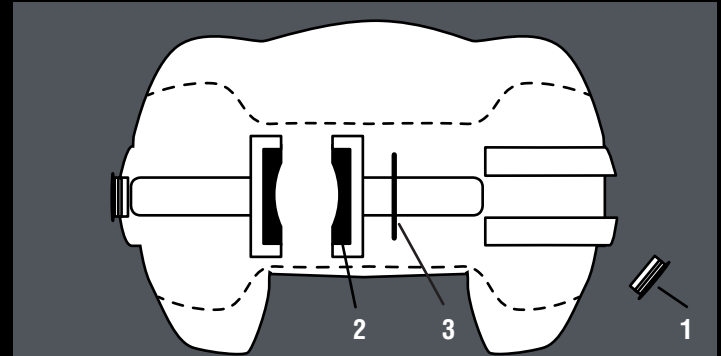

Fig 14 Remove Worn Pads



Fig 15 Insert New Pads

SERVICING AND CLEANING

CHECKING THE EFFICIENCY OF THE FRONT/REAR FRICTION PADS

1. Couple the AKS 3004 stabiliser to the towball but do not activate the stabiliser.
2. If a green indicator is visible (on the handle), then the AKS 3004 is in a new condition or the pads and towball are within the permissible limits (Fig 16/Item 2).
3. If only a red indicator is visible (Fig 17/Item 3), then this may have the following causes:
 - a. AKS 3004 is okay but the towball has reached the lowest limit of 49.61mm.
 - b. AKS 3004 stabiliser shows signs of wear.
 - c. Towball is in a new condition (50mm) but the front/rear friction pads show a high degree of wear.

Establish the diameter of the towball so that conclusions may be drawn as to the wear of the friction pads (ball diameter must not be less than 49.61mm).

FRICTION PAD REPLACEMENT (FRONT/REAR)

1. Uncouple the AKS 3004 stabiliser.
2. Remove the soft dock (pull up & off), (Fig 20/Item 1).
3. Press the safety indicator outwards and secure with SW14 hex. spanner (not included), (Fig 20/ Item 2).
4. Remove cheese-head screw (Fig 20/Item 3 & Fig 18), using special torx tool.
5. Press friction lining recess (Fig 20/Item 4) inwards and pull down and out.
6. Open coupling handle (Fig 20/Item 5).
7. Remove countersunk head cap screw using special torx tool (Fig 20/Item 6 & Fig 19).
8. Press friction pad inwards with a screwdriver and remove.
9. Fit new friction pads in reverse. Tighten screws to 5Nm (Fig 20/ Items 3&6)
10. Replace rubber soft dock, insert top section then bottom.

SERVICING AND CLEANING

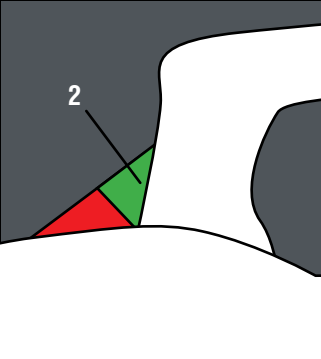

Fig 16 Wear indicator - good condition



Fig 18 Cheese-head screw revealed

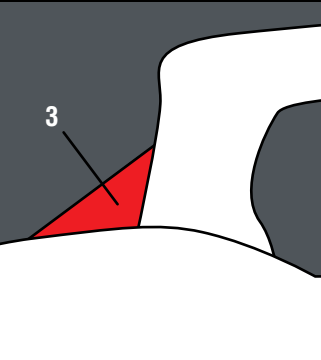

Fig 17 Wear indicator - poor condition



Fig 19 Remove Head Cap Screw

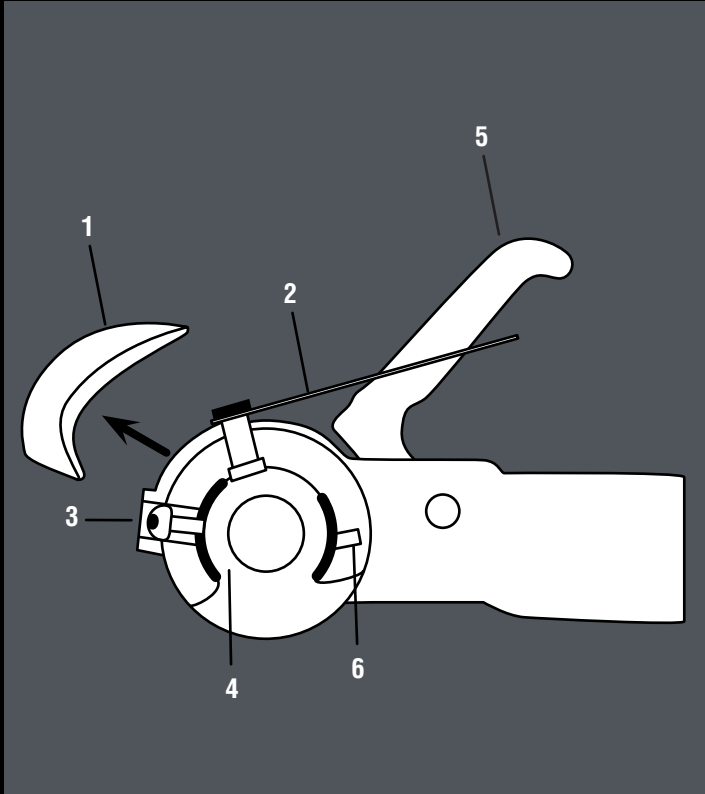

Fig 20 Friction Pad Replacement

SERVICING AND CLEANING

IMPORTANT MAINTENANCE & CLEANING ADVICE

1. The towball should be cleaned regularly to remove grease or other residue, to maintain the efficiency of the friction pads. The use of thinners, white spirit or brake cleaner is recommended for cleaning the towball and friction pads.
2. If friction pads are contaminated, they should not be cleaned but replaced.
3. The surface of the towball must be free of grooves, rust or seizing marks.
4. Towballs coated with paint or similar, must have this surface completely removed (use 100 or 120 grain emery paper). If this is not done, increased towball wear will occur and may cause damage to the AKS 3004 stabiliser components.
5. In winter, you should carefully spray only the visual indicator with de-icer.

LUBRICATION

Should lubrication of the stabiliser parts become necessary, then the following must be observed.

- a. Clean all parts thoroughly.
- b. Areas may only be covered with a thin film of grease (Fig 21).
- c. Use multipurpose grease DIN 51825 KTA 3K.

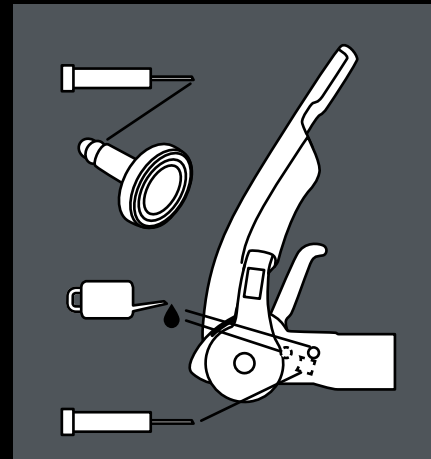

Fig 21 Lubrication points

WARNING

When lubricating, ensure none gets into the friction pad or towball holding area.

FAQS

STABILISER

CAN THE RED AND/OR GREEN INDICATOR BUTTONS BE REPLACED IF BROKEN/MISSING?

This is usually caused by catching the button with the hitch lock when fitting the hitch lock. The green section can in some circumstances be replaced. Please contact AL-KO for further advice.

The red part cannot be replaced.

THE STABILISER ARMS KEEP LIFTING UP WHEN I TRAVEL.

The most likely cause is the handbrake handle catching on the stabiliser lever when braking.

Gently tease the handle away from the contact point - 5mm should be sufficient. Whilst doing this, make sure you support the base of the handbrake with a block of wood to stop it coming off the ratchet plate.

FRICTION PADS

WHEN SHOULD I CHANGE MY FRICTION PADS?

The friction pad life expectancy is around 30,000 miles and can be prolonged by regular cleaning with fine grade emery paper. Simply remove them according to the instructions on pages 15-17, clean them and replace.

However, they will wear out and this can be monitored via wear indicators on your stabiliser. See pages 14-17 for wear indicator information, and instructions on changing them.

MY FRICTION PADS LOOK 'GLASSY' WITH BITS FLAKING OFF.

Contamination has built up on the pads. This could be due to grease on the towball, spray from the road, diesel fumes or failure to remove all of the coating on the towball.

You need to remove the friction pads according to the instructions on pages 15-17, and rub them lightly with a fine grade emery paper. AL-KO recommend cleaning the pads in this way after every journey to prevent build up and prolong friction pad life.

FAQS

WHEN TOWING I CAN HEAR LOUD CREAKING OR GROANING.

2 possible causes:

- 1 The incorrect towball could be fitted. Check your towball is compatible with your stabiliser, and if it isn't replace it immediately. Failure to do so could result in your caravan becoming unhitched during towing.

The necessary clearances are outlined on page 4, and AL-KO recommends the AL-KO extended neck towball which complies to all the necessary specifications.

- 2 Contamination may have built up on the friction pads. This could be due to grease on the towball, spray from the road, diesel fumes or failure to remove all of the coating on the towball.

You need to remove the friction pads according to the instructions on pages 15-17 and rub them lightly with a fine grade emery paper.

AL-KO recommend cleaning the pads in this way after every journey to prevent build up and prolong friction pad life.

THE END HAS SNAPPED OFF OF MY FRICTION PAD.

This usually happens when the pads have not been fully disengaged before dropping the stabiliser onto the towball. You will need to replace the friction pad with a new one. To avoid this in future always place, rather than drop, the stabiliser onto the towball and ensure the stabiliser lever has been lifted fully.

CAN I TOW MY CARAVAN WITHOUT ACTIVATING THE FRICTION PADS?

Yes, but AL-KO do not recommend it. It is the hitch handle that attaches the stabiliser to the towball. If you do not activate your friction pads then you will have no damping benefits.

TOWBALL

MY TOWBALL HAS GREASE ON IT. CAN I USE IT WITH AN AKS STABILISER?

Under no circumstances can a greased towball be used with an AKS stabiliser. Ensure you remove all grease before hitching up. Use a cloth to remove the excess grease, and use brake cleaner to remove any residue. We do not recommend methylated spirit as this can leave a greasy residue.

FAQS

I HAVE AN AKS 3004 STABILISER. WHAT IS THE MINIMUM CLEARANCE THAT I NEED BETWEEN THE TOWBALL AND TOWING VEHICLE?

Minimum clearance is 68mm. This measurement is taken from the centre of the towball to the nearest point of contact with the towing vehicle.

Insufficient clearance will prevent the stabiliser from correct articulation and could damage your car or even cause the stabiliser to become detached from the towball.

WHICH TOWBALLS ARE COMPATIBLE WITH THE AKS 3004 STABILISER?

The necessary clearances are outlined on page 4, and AL-KO recommends the AL-KO extended neck towball which complies to all the necessary specifications.

The AL-KO extended neck towball is available to purchase online at www.al-ko.co.uk.

I HAVE A NEW AL-KO TOWBALL - DO I NEED TO TAKE THE PAINT OFF?

Yes. It is vital that all paint is removed from the towball before use, as it will contaminate the stabiliser friction pads.

To remove the paint, simply rub with emery paper, ideally finishing with a coat of brake cleaner fluid to remove any residue.

COMPLEMENTARY PRODUCTS

AL-KO SECURITY DEVICE

AL-KO Security Devices provide a substantial deterrent against the theft of the caravan or trailer. They lock over the coupling handle, preventing unauthorised uncoupling.

Fitting the supplied Safety Ball into the coupling head when the Security Device is applied, prevents the caravan or trailer from being coupled to another vehicle.

The Security Device is manufactured from high density steel and is TUV approved.

Visit www.al-ko.co.uk for more information.

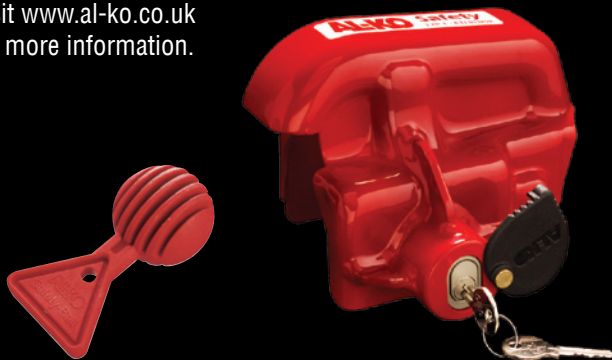

FRICTION PADS

Made from low-wear material, four specially engineered friction pads surround the towball and continue to ensure optimum friction damping.

EXTENDED NECK TOWBALL

Designed especially for use with the AL-KO AKS stabilisers the Extended Neck Towball has an extended machined neck to allow correct stabiliser articulation and clearances.



HITCH COVER

Designed to fit the AKS 3004 Stabilisers, the hitch cover will help protect your stabiliser from the elements.

The water/fade resistant padded foam fabric has a velcro fastening and eyelet for padlock security (padlock not included).

Visit www.al-ko.co.uk for more information.



COMPLEMENTARY PRODUCTS

AL-KO ATC TRAILER CONTROL

ATC Trailer Control is an electronic braking device for caravans and works in a similar way to ESP on some tow cars. ATC monitors for instability and takes the necessary action to prevent the caravan from snaking by gently applying the caravan brakes, extending the distance between the tow car and caravan and bringing the caravan back into line. ATC has been fitted as standard on a wide range of caravans since its launch in 2007 and is also available for retrofit.

For more information on how ATC works, please visit our website at www.al-ko.co.uk.



THE AL-KO FORMULA FOR OPTIMUM SAFETY

The AL-KO Formula for Optimum Safety is a combination of industry leading technology that ensures the safest possible driving conditions for caravan owners. When used in conjunction with AL-KO AKS, there is no safer package for towing a caravan.

The AL-KO AKS Stabiliser device permanently suppresses small swinging and pitching movements in the trailer and increases the critical driving speed by approx 20%.

As an emergency system, AL-KO ATC automatically safeguards against a number of critical driving conditions.

A safe driving style and correct loading combine with AL-KO's advanced technology to ensure optimum safety and unparalleled towing stability.

