

Accessories

Spare Wheel Carrier

AL-KO

Vehicle Technology

Product Features

- Zinc plated for all weather protection.
- Carrier can be fitted for left or right hand operation.
- Ideal location for weight distribution.
- 4 versions to fit most caravan chassis.
- Provision for securing with a padlock.



Spare Wheel not included



Perhaps the most important spare that a caravan or trailer should carry is the spare wheel, the problem is where to stow it. AL-KO can provide the ideal solution, a spare wheel carrier that is easy to fit, easy to use, and zinc coated to provide all weather protection.

Most caravan chassis have pre-punched holes in the chassis members approximately 700mm rear of the axle. These pre-punched holes are on both sides of the chassis which enables the carrier to be fitted with the telescopic action operating to either the left or right hand side. This ensures that wheel removal can always be to the nearside of the road, whether driving on the left in the UK, or on the right in Europe.

The position of the carrier, within the chassis frame, and close to the axle is the ideal location with regard to weight distribution.

There are four versions of the AL-KO spare wheel carrier to cover caravans with chassis member widths between 1050-1815mm. To determine which model is suitable for your caravan refer to 'specifications' on the reverse side of this leaflet.

The carrier is secured by a plastic knurled knob on the locating pin fitted to the side plate. This locating pin has a hole which enables a spring clip to be inserted to prevent the securing plastic knob from becoming detached due to vibration. It can also be used to pass a shackle lock through to lock the carrier in situ.

The carrier is supplied boxed with all fittings and clear instructions for assembly and use*. On assembly the wheel locating plate should be positioned slightly towards the operating side of the carrier. This ensures that the telescopic arms can be withdrawn sufficiently to allow the spare wheel to clear the chassis member for easy removal.

To make sure that the spare wheel and the AL-KO spare wheel carrier are kept in optimum condition remember to regularly lubricate the telescopic tube: check the spare tyre for correct pressure and damage. Never put a damaged tyre back on the carrier as it is easily forgotten, remember to have it replaced or repaired.

*For your convenience - Pt 128 7180 comes pre-assembled

Accessories

Specification and Technical Data

Step 1 - Measure distance between the chassis members and refer to figure 1 for correct part number.

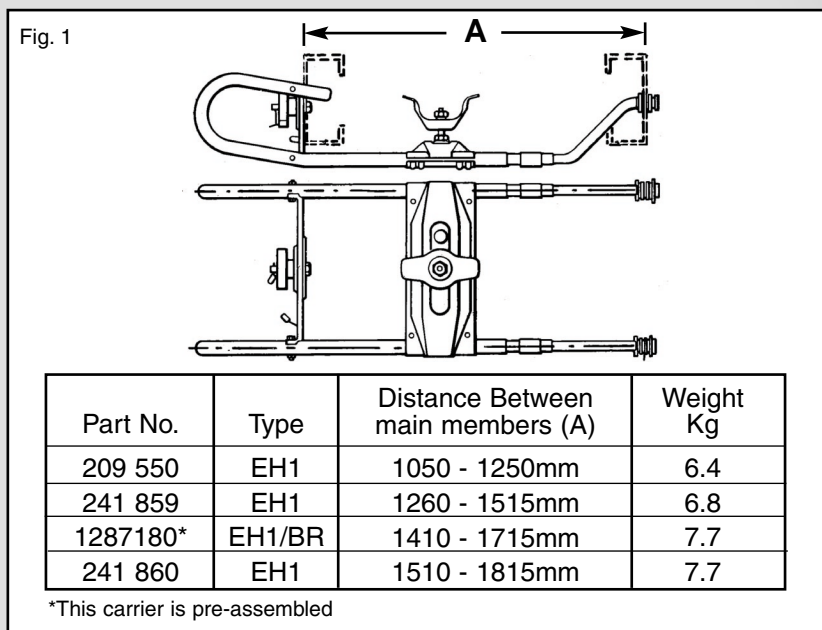

Step 2 - Check which tyre size is fitted to your caravan (eg. 195 R13).

Step 3 - Measure the distance marked 'X' on the actual caravan chassis main member (refer to Fig. 2)

Step 4 - Refer to table 1 to check Dim 'X' against maximum tyre size suitable for that particular caravan/spare wheel carrier configuration.

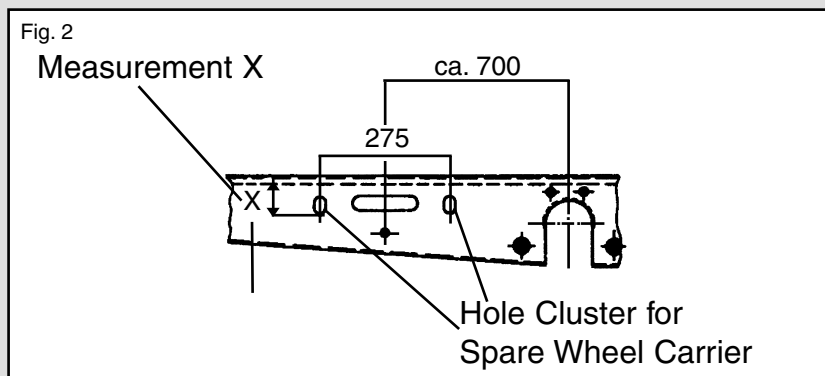

Table 1.

Dim X (mm)	Maximum Tyre Size for 209550	Maximum Tyre Size for 241859/241860/1287180
75	155 R13	175 R13, 175 R14, 175/70 R14
85	165 R13	185 R13, 185 R14
95	175 R13, 175 R14, 175/70 R14	195 R13, 195 R14, 195/70 R14
105	185 R14	205/70 R14, 205/70 R15
115	195/70 R14	205/70 R14, 205/70 R15
125	205/70 R14, 205/70 R15	