

CARVER



CASCADE 2

&

CASCADE 2 GE

CARAVAN WATER HEATER

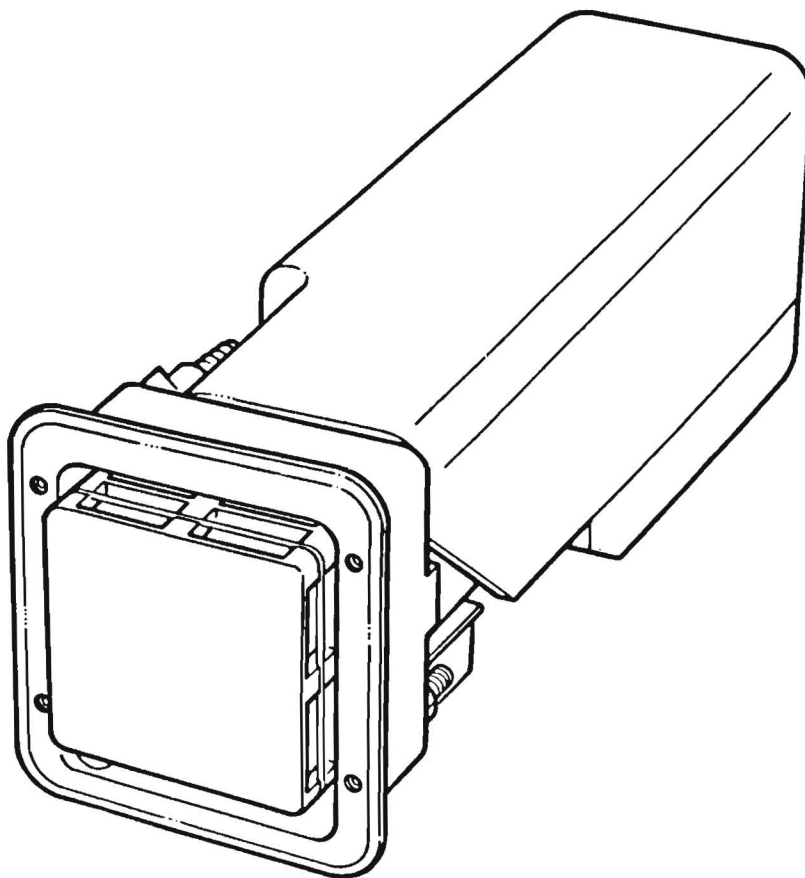

INSTALLATION INSTRUCTIONS

LEAVE THESE INSTRUCTIONS WITH THE USER

1:0 SPECIFICATIONS

Water capacity	9 litres (2 gallons)
Water connections	Male nozzles to suit 12mm bore reinforced hose. The cold inlet incorporates a non-return valve.
Water supply	Maximum recommended pressure from pump 1.4bar (20p.s.i.) or from header tank 13m (40ft) head.

NOT SUITABLE FOR DIRECT CONNECTION TO THE MAINS WATER SUPPLY.

Weight	Empty	5.64(12.4 lbs)
	Full	14.64 (32.4 lbs)

OPERATION	GAS	MAINS ELECTRIC
	Cascade 2 & 2GE	Cascade 2 GE only
Temperature Range	52 ⁰ C-70 ⁰ C adjustable	70 ⁰ C approx. non-adjustable
Insulation Heat Loss	3 ⁰ C per hour	3 ⁰ C per hour
Efficiency	Better than 75%	N/A
Gas Connection	Female DIN coupling to suit 8mm or ¼” o/d copper pipe.	N/A
Gas Supply Pressure	Butane at 28 mbar OR Propane at 37 mbar	N/A
Gas consumption	87 gm/hr (3oz) when tiring. Approx 140 grams (5oz) per day to supply 23 litres (5 gallons) of hot water.	N/A
Electrical Supply	Nominal 12v DC Negative earth only	220-240v AC. 50Hz
Electrical Consumption	250 mA Heating 25 mA Standby	2.75A at 240v (660w) 2.5A at 220v (605w)
Fuses	2 x 1A in controller	Not Supplied. 5A recommended
Warm up Time	Typically some water at 55 ⁰ C to 60 ⁰ C available after 30 mins of switching on.	Typically some water at 55 ⁰ C to 60CC available after 55 mins of switching on.
User Control	Remote controller with indicator lights, supplied with heater.	Not supplied. Recommended Double Pole illuminated switch outlet with a contact gap of at least 3mm in each pole and fused at 5 amp.
Safety Features	Pressure relief valve set at 3 bar and fusible plug Set at 96 ⁰ C both venting onto burner.	As Gas Only plus over temperature thermostat with manual reset set at 85 ⁰ C
Other Features	The electronic burner control features protection against flame failure, gas supply interruption and low voltage.	

2:0 WARNINGS AND INFORMATION

This heater must be installed by a competent gas fitter working to the Gas Safety (Installation and use) Regulations 1984, and as amended 1990, the Health and Safety at Work Regulations and these Fitting Instructions.

In addition the installation of the mains electrics for the Cascade 2 GE must be carried out by a competent electrician working to the IEE Regulations 16th edition 1991 and these Fitting Instructions.

For **USER SAFETY** attention is drawn to Section 4.1 i.e. Balanced Flue Terminal Position.

The gas control circuit must only be connected to a 12volt dc. negative earth supply.

Before commencing any work on the caravan disconnect the battery and isolate the caravan from the mains supply.

Mains connection for the Cascade 2 GE should be made via a double pole switched outlet with a contact gap of at least 3mm in each pole.

Water hoses should be reinforced, opaque **FOOD QUALITY**.

Cascade 2 GE mains cable must be less than that recommended, i.e. 3 core (blue, brown and green/yellow) with a CSA of 0.75mm².

This heater does not contain asbestos or asbestos related products.

The Cascade 2 and Cascade 2 GE are approved to the relevant sections of B.S. 5258 part 7.1977 and B.S. 3456 part 101. 1987 and part 102. section 102. 15 under The National Measurement Accreditation Service (NAMAS), and are manufactured to B.S. 5750 part 2 1987. The heaters are suitable for installation into caravans complying with B.S. 4626. 1970. The data badge is located on the bulkhead behind the flue cowl or on the outside of the bulkhead to the left hand side when viewed from the rear.

3:0 THE HEATER KIT

The heater kit consists of the following:

- 1 Assembled Heater complete with multicore cable
- 1 Wall switch
- 1 DIN 8mm dia. Olive
- 1 ¼" dia. Olive
- 1 Compression Nut
- 9 Csk. Head Screws
- 4 Stainless steel Pan Head Screws
- 2 Round head Screws
- 1 Set literature

4:0 SELECTING THE POSITION

Choose a flat vertical wall without interference of trims etc. if possible.

Ensure that the overall depth of the heater will fit into the locker or cupboard (see fig 1)

Ensure that any trims can be refitted or cut to make a watertight seal and a neat installation. Structural sections within the walls of the caravan should be avoided for safety reasons.

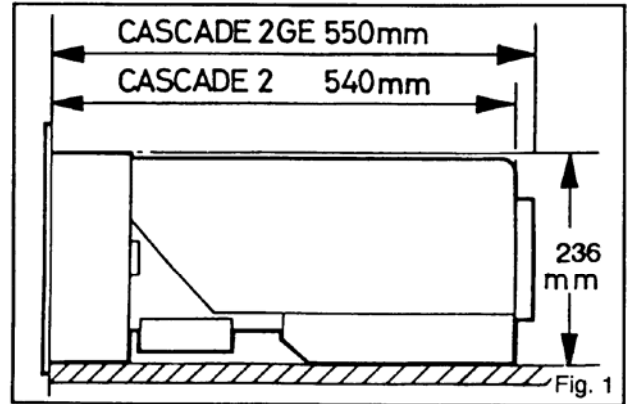

4:1 BALANCED FLUE TERMINAL POSITION

Location	Minimum dimension
A Below an opening window	300mm
B Vertical corner	600mm

(see fig 2)

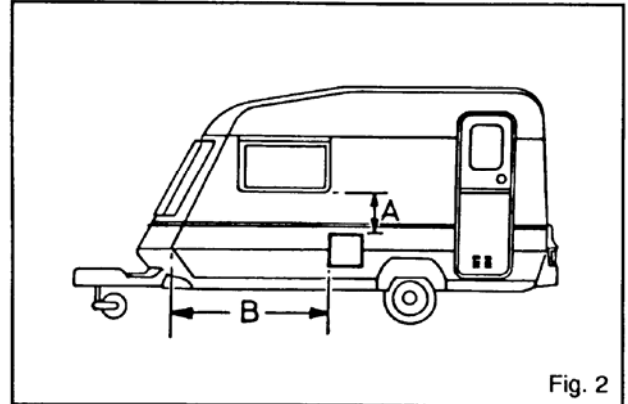

5:0 CUTTING THE HOLE

At the centre fold of these instructions you will find a sheet of paper on which is printed the template for the heater fitting and the wall switch. Remove the template from these instructions (see fig 3.) and separate it into two templates

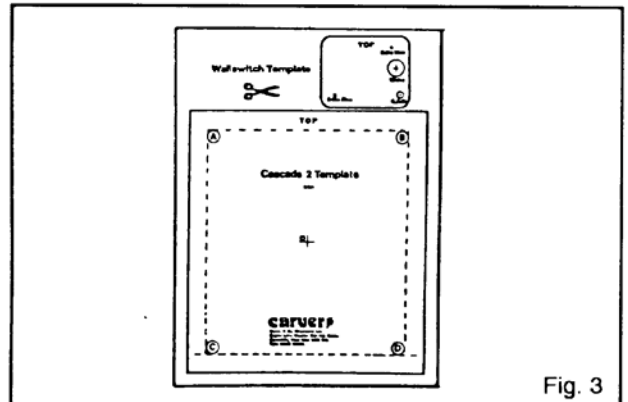

6:0 INSIDE THE CARAVAN

Temporarily tape the template to the inside wall at the position required. Ensure that the bottom of the template, i.e. the line CD, is to the floor or above any strength beam in the base of the wall. Mark the 'O' position through the template onto the wall.

Remove the template and drill a 4mm dia. hole through the inner and outer walls at the 'O' position. Ensure that the drill is kept square to the wall.

7:0 OUTSIDE THE CARAVAN

The pilot hole drilled through the wall will allow the template to be positioned correctly on the outside wall.

Tape the wall template (see fig 4.) and align the 'O' position with the previously drilled hole. Ensure that the template is square to the caravan body. The line CD should be level with the caravan floor or above any strength beam on the base of the wall.

Drill four 10mm dia. Holes at the positions A, B, C, & D as shown on the wall template. The drill should pass through the inner and outer walls. Using a jigsaw or padsaw cut to the lines shown on the template. (see fig 5)

Remove all traces of the template and masking tape from the caravan wall.

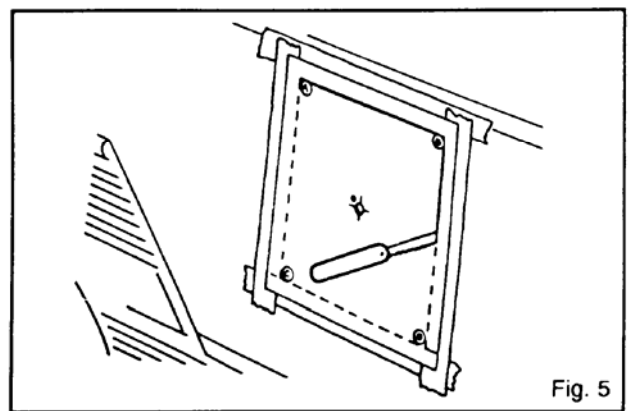
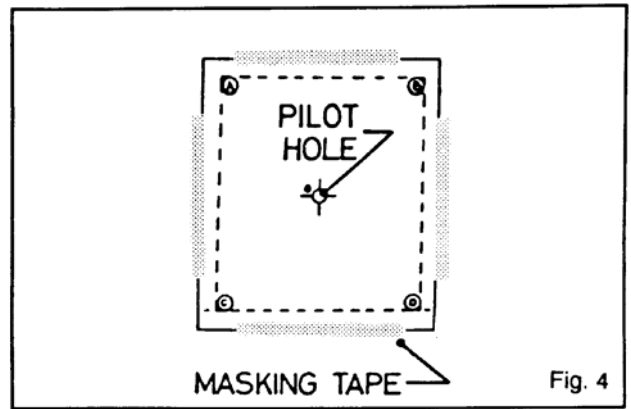

8:0 LINING THE HOLE

The hole in the caravan wall must be lined with timber to give a firm support for holding the heater in position. (see fig. 6)

Before fining the timber lining first remove any insulation from between the inner and outer walls to the depth of the timber. The finished hole size should be 240mm x 212mm.

Use a silicone sealant to seal the lining to the inner and outer walls. Secure the inner walls to the lining with panel pins. The panel pins should be fined within 10mm of the edge of the hole at the top and sides only. Trim the edges of the hole to remove any burrs etc... The use of silicone sealant is to prevent water from entering the walls and floor of the caravan.

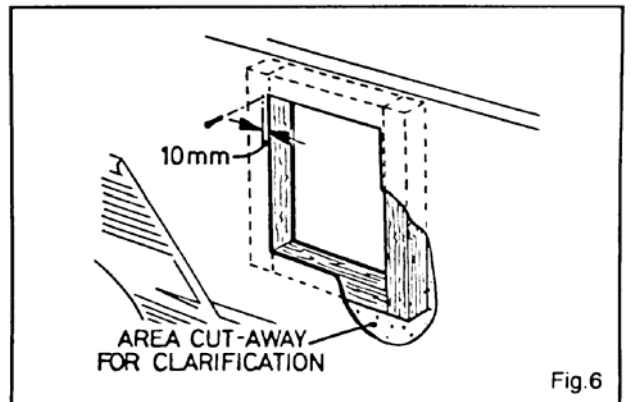

9:0 240 VOLT CONNECTION (GE ONLY)

Any work on mains electric should be carried out by a competent electrician working to the current IEE Regulations.

Ensure the caravan is isolated from the mains supply before starting any work.

The illumination double pole switched outlet fused at 5 amp should be located in a position convenient for easy operation by the user, ie. on the outside of the bedding locker adjacent to the Cascade 2 GE. The mains cable should be connected from the fused outlet to either the RCCB or joined into the existing wiring via a 15 amp junction box.

The cable required to connect the Cascade 2 GE to the fused mains outlet should be to a minimum standard of 3 core double sheathed (blue, brown and green/yellow) with a cross sectional area of 0.75mm^2 . Estimate the length of cable required from the fused outlet to the Cascade 2 GE and allow extra to enable the heater to be partially withdrawn through the side of the caravan without disconnection.

Remove the plate covering the electrical connections of the Cascade 2 GE.

Prepare the end of the cable as shown in fig. 7. Pass the prepared end through the cable entry and under the cable clamp.

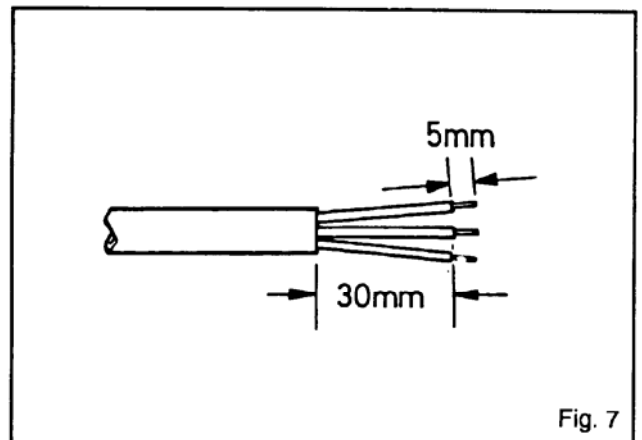

Connect the cable into the three way terminal block (see fig 8). The brown wire is connected to the terminal marked 'L', blue to the 'N' and the green/yellow to the 'E'

Tighten the cable clamp taking care not to damage the cable or screws.

Replace the cover plate with the 3 screws provided.

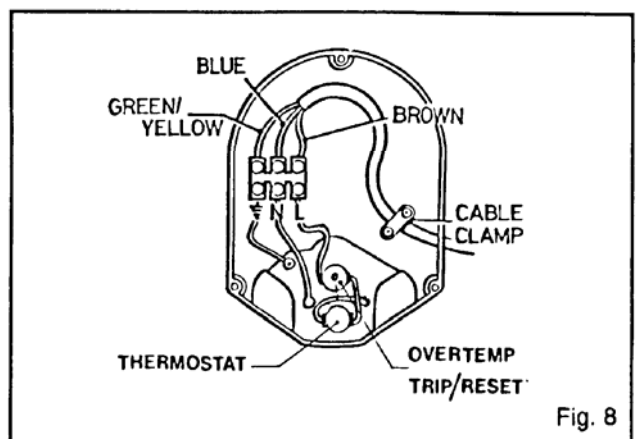

10:0 WATER CONNECTIONS

10:1 Use ONLY reinforced FOOD QUALITY opaque hose to avoid unpleasant tastes and smells in the water.

Note: the reason for the use of opaque hose is that this reduces the possibility of the build up of algae in the system.

10:2 When connecting into the water supply pipes it is advisable to use a 'Y' connector as this does not reduce the flow to the same degree as a 'TEE'. (see fig.9)

Connect the cold feed hose for the heater to the existing cold water supply by the use of a 'Y' connector. Allow enough length on the hose to make the connection to the heater through hole in the wall of the caravan (see fig. 10).

Complete the hot water system allowing enough hose to make the connection to the heater through the hole in the caravan wall.

10:3 Pumps & Taps

Taps which control the pump by a switch in each tap are considered most suitable but the heater will also work on systems using a pressure switch to control the pump (provided that the pressure operating the switch is below 1 .4bar). Where a pressure switch is used temperature fluctuations can be expected when showering.

11:0 FITTING THE HEATER

11:1 Ensure that the DIN plug is connected to the electronics module at the bottom of the heater.

Offer the heater through the hole in the wall making sure that the multicore cable and the 240volt cable in the case of the C2GE are not trapped under the heater.

Make the water connections... The cold water inlet is fitted to the bottom hose connector of the heater; this connector also incorporates a non-return valve. The hot water flow hose fits to the top connector. Secure the hoses to the connectors using suitable pipe clips. (see fig. 11)

Coat the black flange with a film of mastic to provide a watertight seal with the caravan wall.

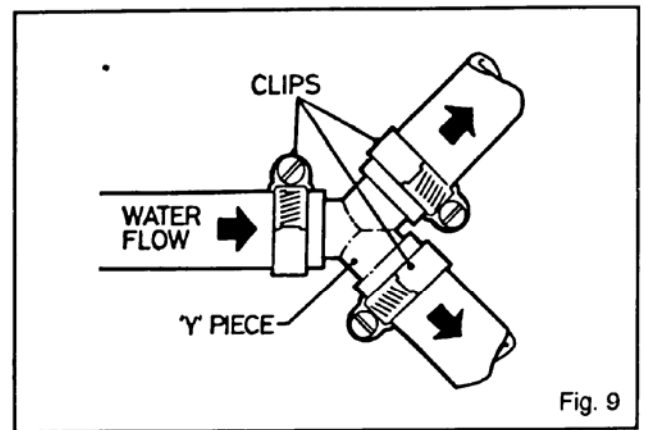

Fig. 9

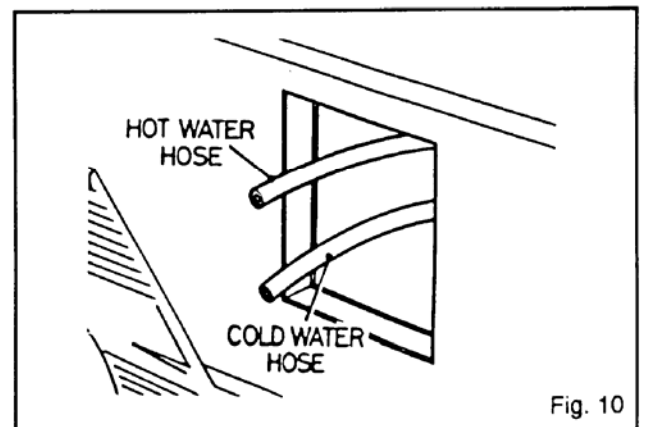

Fig. 10

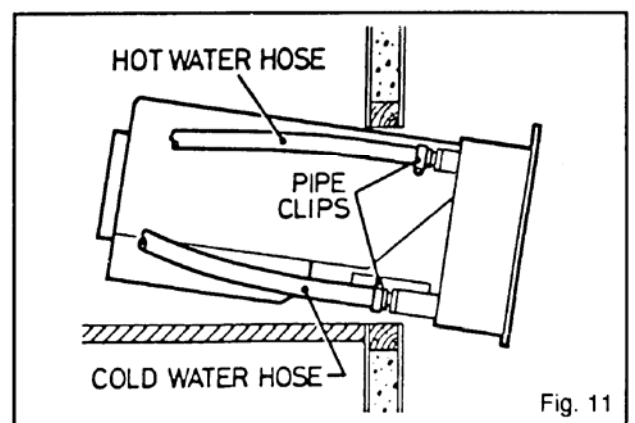
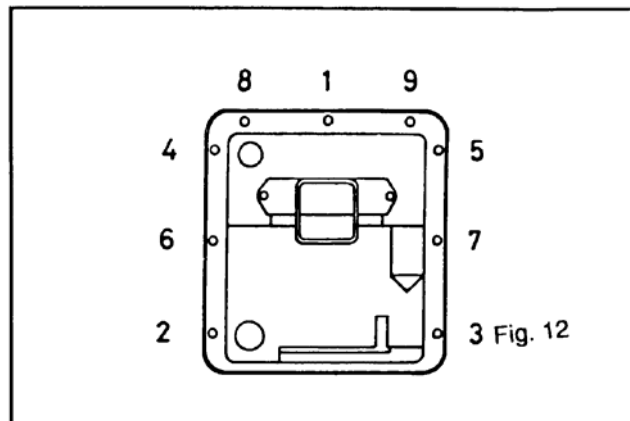

Fig. 11

11:0 CONTINUED

Push the heater fully home and using the flange holes as a guide drill through the outer skin of the caravan wall with a 4mm dia. drill.

Secure the heater flange to the wall by progressively tightening the screws to compress the mastic seal. (see fig.12)



11:2 Remove any excess mastic taking care not to damage the caravan paintwork.

Fix the cowl into position on the flange using the four stainless steel screws. Ensure that the cowl is the correct way up. (see fig. 13)

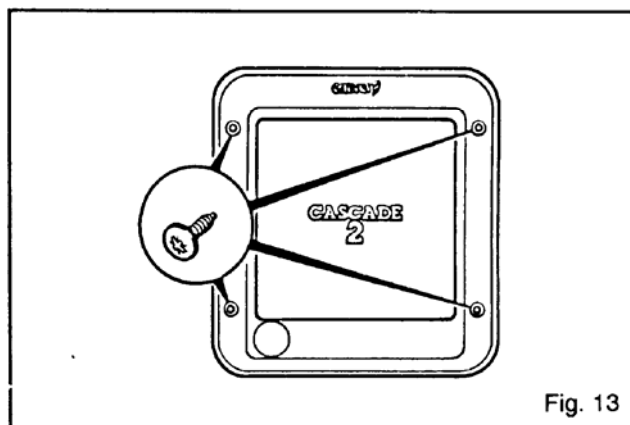

12:0 FINAL 240 VOLT CONNECTION (GE ONLY)

Take note of recommendation made in section 1:0. The 240 volt wall switch should be located in a position convenient for easy operation by the user. e.g. on the outside of the bedding locker. The mains cable should be either directly connected to the RCD or joined into the existing wiring via a 15amp junction box.

Connect the heater cable to the fused outlet supply. Clip the cable securely to the caravan structure and ensure that the cable is long enough to allow partial withdrawal of the heater through the caravan wall for servicing.

13:0 WALL SWITCH

Remove the backing from the wall switch template and place in the required position take note that the multicore cable is only 3 metres long. Therefore run the cable to the wall switch location before drilling any holes. Drill the holes to the sizes shown on the template.

Fix the wall switch with the two screws provided.

Feed the DIN plug through the 18mm dia. hole and connect into the DIN socket. (see fig. 14)

The DIN plug and socket are keyed so that they will only fit one way.

Connect the wall switch to the 12volt supply

The DIN Caravan wiring colour code is as follows:

Green.. .12 volt positive (live)

White.... 12 volt negative (earth)

Note: Some caravans are wired with blue as positive (live) so exercise caution on the 12 volt wiring.

Ensure that the polarity of the wiring to the wall switch is correct. (see fig. 15)

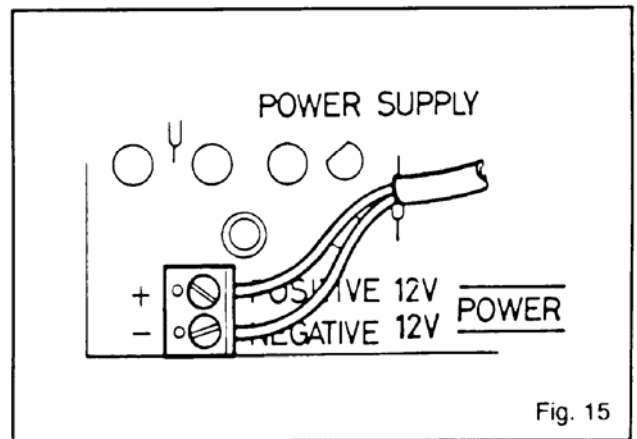
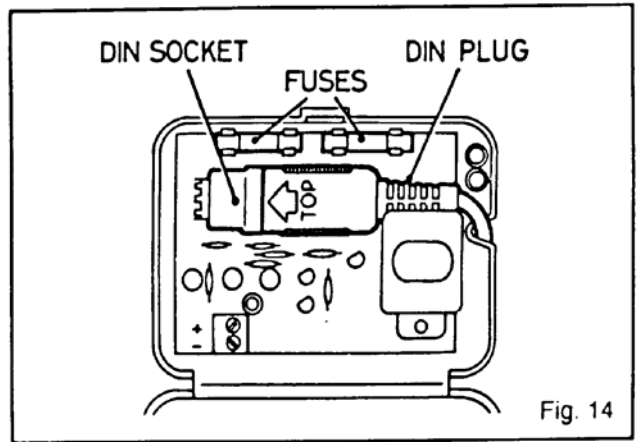

14:0 GAS CONNECTION

Ensure that the gas supply is turned off at the cylinder.

Connect the heater to the caravan gas system via, an approved isolating valve. The gas inlet fitting is suitable for 8mm or 1/4" dia. copper pipe. The 8mm dia. pipe DIN gas fitting should be assembled as in fig. 16. The olive for the 1/4" dia. pipe is symmetrical.

It is recommended that a 25mm dia. gas drop hole be drilled through the floor adjacent to where the gas supply joins the heater. When this recommendation is followed the gas feed must be separated from the bedding locker with an enclosure to maintain compliance with the caravan ventilation regulations. The bedding locker lid may form the top of the enclosure and to give access to the isolating valve.

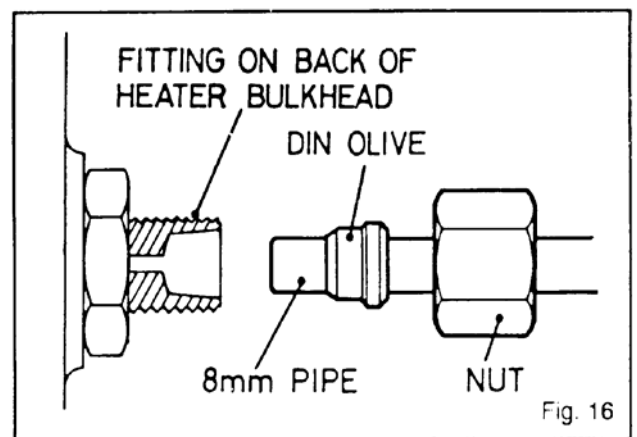

14:0 CONTINUED

Turn on the gas supply at the cylinder and leak test the gas system using soapy water or other approved methods.

15:0 FINAL TEST

Recheck the installation and where necessary clip any pipes and cable securely.

Turn on the gas at the cylinder and at the isolating valve.

Switch on the 12 volt supply.

Place the pump in a full container of water.

Turn on the hot taps and wait until the water flows from the taps, this will indicate that the heater is full of water.

16:0 TO USE GAS HEATING

- 1...Ensure that the gas and 12 volt supply are on.
- 2...Turn on at the wall switch
- 3...If a green light shows continuously then the heater is working satisfactorily.
- 4...If green and red lights show after approx. 10 seconds slide the switch to the off position, wait 3 minutes and switch on again..
- 5...If green and yellow lights show then the voltage to the control is too low. Recharge the battery.

17:0 ELECTRIC TESTING (GE ONLY)

- 1...Ensure that the 240 volt supply to the caravan is connected and that the ROD is switched on.
- 2...Switch on the 240 volt supply to the heater.
- 3...Wait to check that the water is warming.

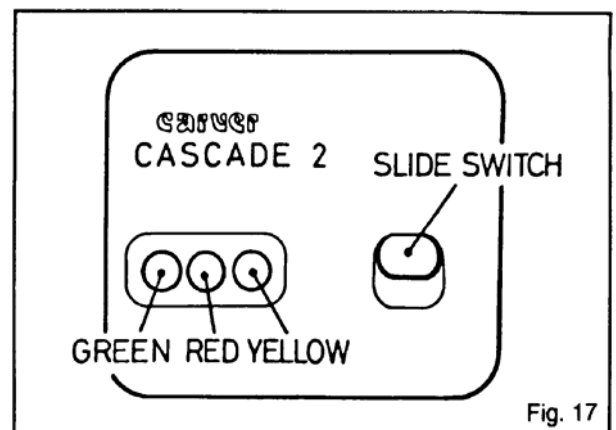

Fig. 17

18:0 HEATER FAULT TRACING

GAS OPERATION			
Primary Symptom	Secondary Symptom	Cause	Cure
When switching on from cold no indicator lights come on	Heater does not operate	Reversed power supply	Check connection from caravan wiring to wall switch
		Power not reaching heater	Check wiring from wall switch to caravan supply
		Fuses not in place or blown	Check for wiring fault and replace fuse
When switching on from cold green light only comes on and stays on.	Heater does not operate No fail light. Igniter not working. Gas valve not working.	Multi-pin plug disconnected at wall switch or heater.	Re-connect multi-pin plug
When switching on from cold green & yellow lights come on	Heater does not operate Battery condition low causing pump to run slowly.	Voltage at wall switch below 10.5v	Charge up caravan battery
When switching on, green light comes on and after 10 seconds the red as well .	When listening to the heater during this sequence a click should be heard followed by intermittent ticking for 10 seconds.	Air in gas supply pipe	Purge pipe by switching off and on again. Repeat if necessary
		No gas supply	Check isolation valves & bottle
		Incorrect gas pressure	
	Intake of flue obstructed	Check and clear	
	Water coming from cowl	Pump pressure too high	
	A click heard but no ticking or ticking but no click	Poor connection at multi-pin plug in wall switch or on heater	Pull out and reinsert plugs
Yellow light comes on when pump is operated	Pump runs slowly	Low battery voltage or inadequate pump wiring	Check and charge battery, If not successful. Check wiring.
Red light comes on after about 30-45 mins. with water and steam from cowl.	No continuous water flow from cowl when pump is running	Pressure relief valve operating on temperature rise	Pump pressure too high
	Continuous water flow from cowl when pump is operated	Fusible plug blown indicating thermostat failure	Do not continue to use heater Seek service attention.
MAINS ELECTRIC OPERATION			
Mains immersion heater does not operate	Indicator light on isolating switch not alight	Caravan not connected to site supply	Connect
		RCD in caravan tripped	Reset and try again. If not successful seek service attention.
		Site supply not adequate	Switch off. Seek warden attention.
	Indicator light on isolating switch alight	Thermostat	Switch off and seek service attention.
		Over temp. thermostat	Reset button.

If fault persists consult your Carver approved dealer.